

**I.S. 1A - 11**

**Industry Standard for**

**Architectural  
Wood Flush  
Doors**



**WINDOW & DOOR  
MANUFACTURERS ASSOCIATION**

**WDMA**

THE WINDOW & DOOR MANUFACTURERS ASSOCIATION

401N. Michigan Avenue, Suite 2200, Chicago, IL 60611

## WDMA Environmental Stewardship Committee

### Statement of Beliefs

- The membership of the Window & Door Manufacturers Association (WDMA) supports the intent of environmental stewardship aimed at protecting the earth's resources including sound environmental practices to protect our air, water, land and the human, animal and plant life of our planet.
- WDMA encourages our members to make the most efficient use of materials and resources, to recycle or reuse materials where economically feasible, and to conduct business in a manner that supports environmental stewardship.
- WDMA supports and defines sustainable forest management as the stewardship of forests that promotes the health, productivity and potential to fulfill relevant ecological, economic and social functions at the local, national and global levels, both today and for future generations. We support programs that promote the use of best forestry management practices and sustainable forestry activity.
- We encourage and support our members to improve their practice of environmental stewardship and will work to assist them and the broader community in the implementation of sound environmental practices.

Approved by the WDMA Board of Directors  
May 18, 2006

# TABLE OF CONTENTS

GREEN PRODUCTS STATEMENT OF BELIEFS	2	TESTS	
FOREWORD		T-1 Show Through or Telegraph	29
WDMA Door Division	4	T-2 Flatness or Warp	29
Architectural Wood Flush Doors	4	T-3 Squareness	29
Introduction	4	T-4 Sanding	30
Performance	4	T-5 Joint Gaps	30
Aesthetics	4	CONSTRUCTION	
Purpose	4	General	31
GUIDE SPECIFICATION CHECKLIST	5	C-1 Face Requirements	31
GLOSSARY	6	C-2 Crossbanding Requirements	31
AESTHETICS		C-3 Core Requirements	31
A-1 Aesthetic Grades for Architectural Wood Flush Doors	12	C-4 Edge Requirements	32
A-2 Face Selection	12	C-5 Vertical and Horizontal Edge/Core Interface	32
A-3 Appearance of Individual Veneer Leaves	13	C-6 Adhesives	32
A-4 Matching Between Individual Veneer Leaves	14	C-7 Construction Details	33
A-5 Assembly of Spliced Veneer Leaves on Door Face	15	C-8 Fire Doors	36
A-6 Appearance of Doors in Pairs or Sets	16	C-9 Special Function Doors	37
A-7 Appearance of Doors with Transoms	17	C-10 Environmental Doors	37
A-8 Flush Door Face Veneer Characteristics	17	C-11 Face, Edge, Moulding and Transom Matching Standards	38
A-9 Fabrication	26	C-12 Door Construction Details	39
PERFORMANCE		FINISHING	
P-1 Performance Standards for Architectural Wood Flush Doors	27	General	44
P-2 Example Duty Level Applications	27	F-1 Factory Finishing	44
P-3 Dimensional Information	28	F-2 Finish Selection	44
P-4 Flame Spread Smoke Development	28	F-3 Finish System Descriptions	45
		F-4 Sample Submission	46
		F-5 Job Site Finishing	46
		F-6 Visual Inspection Standards	46
		F-7 Standard Wood Door Finishing System Ratings	47
		JOB SITE INFORMATION	
		How to Store, Handle, Finish, Install and Maintain Wood Doors	48
		REFERENCE STANDARDS AND ORGANIZATIONS	50

Published By:

Window and Door Manufacturers Association  
401 North Michigan, Suite 2200  
Chicago, IL 60611

® Copyright August 2011

No part of this publication may be reproduced in any form, in an electronic retrieval system or otherwise, without the prior written permission of the publisher.

# FOREWORD

## WDMA Door Division

The architectural wood flush door manufacturer and material supplier members of the WDMA Door Division combine to promote the use of architectural wood and laminate doors, to maintain quality standards and to provide other informational services.

Acceptance, specification and other use of this standard is completely voluntary, as the WDMA does not in any way control or regulate the method or manner of manufacture or production of industry products by its various members.

Because of constant technological changes and product improvements in component parts used by wood door manufacturers, industry standards referenced in this document may become outdated. This standard is under constant review so that situations such as these can be evaluated, recognized, and incorporated as quickly as possible. It is the intent of this standard to define wood doors consistent with industry practices and technical advances. This version (2011) takes precedence over previous versions

## Architectural Wood Flush Doors

An architectural wood flush door is the pinnacle of wood door manufacturing. Architectural wood flush doors are part of the building's permanent furniture. The requirements for their manufacture are, therefore, indicative of their place as the building's permanent, visible, operable equipment.

## Introduction

WDMA I.S.1A is a general industry standard that establishes expectations for the performance and aesthetic attributes of architectural wood flush doors. These combine in producing a wood flush door for a particular opening. Function and performance are primarily controlled by the wood door construction. Aesthetics are primarily controlled by species, veneer cut, matching of veneers and finish selected, or by the laminate selected.

## Performance

WDMA standards require the designation of a performance duty level in addition to an aesthetic grade. Performance duty levels are based on the amount and severity of use. There are three levels of duty based on performance values of eight different attributes as defined in the Section P. It is the responsibility of the specifier to select the duty level for each application. Duty levels include:

<b>Extra Heavy Duty</b>	Typically involves doors where use is considered heavy and frequent, and requires the highest minimum performance standards.
<b>Heavy Duty</b>	Typically involves doors where usage is moderate, and requires intermediate minimum performance standards.
<b>Standard Duty</b>	Typically involves doors where frequency of use is low, and requires the lowest minimum performance standards.
Note: If the performance duty level is not specified, Heavy Duty is the default.	

## Aesthetics

Aesthetics are influenced by several factors, as indicated in Section A. However, objective attributes are defined through the use of two grading levels. It is the responsibility of the specifier to select the best aesthetic grade for each application.

<b>Premium</b>	Uses AA grade faces that are assembled using book and center balance match; other face options are available but must be specified. Typically specified for use in those areas of a project where the very highest level of quality is required.
<b>Custom</b>	Uses A grade faces that are assembled using book and running match; other face options are available but must be specified. Typically specified for most high-quality, architectural woodwork. Since Custom Grade satisfies the aesthetic needs for the majority of projects, this is the default grade if aesthetic grade is not specified.
Note: If the aesthetic grade is not specified, Custom grade is the default.	

## Purpose

The purpose of this publication is to:

- Define the aesthetic grades and performance duty levels of architectural wood flush doors available through this standard.
- Provide general information, standards, and tests that will ensure all products complying with this standard can be evaluated on an equal basis.
- Provide a logical, simple system of references, keyed to guide specifications, which will enable the architect to specify wood flush doors thoroughly, precisely, and accurately.
- Provide information necessary for the specifier to identify products and by which products are to be evaluated.
- This Standard applies to architectural wood flush doors intended for interior application. Doors specified to meet this standard are not recommended for exterior use.

# GUIDE SPECIFICATIONS CHECKLIST

The following is a listing of the basic information required in a specification for architectural flush wood doors. The WDMA recommends that these pieces of information appear in any specification for those products. Providing this minimal amount of information will assure clear communication regarding the construction of the doors specified.

<p><b>Wood Face Requirements:</b></p> <p>Veneer Grade (Section A-2)</p> <ul style="list-style-type: none"> <li><input type="checkbox"/> AA (Default Premium)</li> <li><input type="checkbox"/> A (Default Custom)</li> </ul> <p>Veneer Cut (Section A-3)</p> <ul style="list-style-type: none"> <li><input type="checkbox"/> Plain Sliced</li> <li><input type="checkbox"/> Rotary</li> <li><input type="checkbox"/> Quarter Cut</li> <li><input type="checkbox"/> Rift Cut (Oak only)</li> </ul> <p>Veneer Species (Section A-8)</p> <ul style="list-style-type: none"> <li><input type="checkbox"/> As Specified</li> </ul> <p>Veneer Leaf Match (Section A-4)</p> <ul style="list-style-type: none"> <li><input type="checkbox"/> Book (Default)</li> <li><input type="checkbox"/> Slip</li> </ul> <p>Veneer Face Match (Section A-5)</p> <ul style="list-style-type: none"> <li><input type="checkbox"/> Running (Default Custom)</li> <li><input type="checkbox"/> Balance</li> <li><input type="checkbox"/> Center Balance (Default Premium)</li> <li><input type="checkbox"/> Other _____</li> </ul> <p>Appearance of Pairs, Sets and Transoms (Sections A-6 and A-7)</p> <ul style="list-style-type: none"> <li><input type="checkbox"/> Matched</li> <li><input type="checkbox"/> Not Matched</li> </ul> <p><b>HPDL Face Requirements:</b></p> <ul style="list-style-type: none"> <li><input type="checkbox"/> Manufacturer</li> <li><input type="checkbox"/> Thickness</li> <li><input type="checkbox"/> Pattern/Color/Finish</li> </ul> <p><b>LPDL Face Requirements:</b></p> <ul style="list-style-type: none"> <li><input type="checkbox"/> Manufacturer</li> <li><input type="checkbox"/> Pattern/Color</li> </ul> <p><b>Detailed Requirements:</b></p> <ul style="list-style-type: none"> <li><input type="checkbox"/> Wood Beaded Lites</li> <li><input type="checkbox"/> Metal Vision Panels</li> </ul> <p><b>Finish Requirements:</b> (Section F-1)</p> <p>Finish Application</p> <ul style="list-style-type: none"> <li><input type="checkbox"/> Factory Clear</li> <li><input type="checkbox"/> Factory Stain</li> <li><input type="checkbox"/> Factory Opaque</li> <li><input type="checkbox"/> Other _____</li> </ul>	<p><b>Door Construction:</b></p> <p>Aesthetic Grade (Section A-1)</p> <ul style="list-style-type: none"> <li><input type="checkbox"/> Premium</li> <li><input type="checkbox"/> Custom</li> </ul> <p>Performance Duty Level (Section P-1)</p> <ul style="list-style-type: none"> <li><input type="checkbox"/> Extra Heavy Duty</li> <li><input type="checkbox"/> Heavy Duty</li> <li><input type="checkbox"/> Standard Duty</li> </ul> <p>Core Type (Section C-3)</p> <ul style="list-style-type: none"> <li><input type="checkbox"/> Particleboard (PC)</li> <li><input type="checkbox"/> Staved Lumber Core (SLC)</li> <li><input type="checkbox"/> Structural Composite Lumber (SCLC)</li> <li><input type="checkbox"/> Fire Resistant Composite (FD)</li> <li><input type="checkbox"/> Hollow core</li> </ul> <p>Hardware Blocking (See Section C-7)</p> <ul style="list-style-type: none"> <li><input type="checkbox"/> Hardware Reinforcement Blocking Core/Edge Interface (Section C-5)</li> <li><input type="checkbox"/> Bonded</li> <li><input type="checkbox"/> Non-Bonded</li> </ul> <p>Fire Door Test Method (Section C-8)</p> <ul style="list-style-type: none"> <li><input type="checkbox"/> UBC 7-2-1994 Neutral Pressure</li> <li><input type="checkbox"/> UBC 7-2-1997 Positive Pressure</li> </ul> <p><b>Special Function Doors:</b> (Section C-9)</p> <ul style="list-style-type: none"> <li><input type="checkbox"/> Sound Resistant (STC)</li> <li><input type="checkbox"/> Lead Lined (X-Ray)</li> <li><input type="checkbox"/> Bullet Resistant</li> <li><input type="checkbox"/> Electrostatic Shield</li> </ul> <p><b>Environmental Doors</b> (Section C-10)</p> <p>Environmental Rating Program</p> <ul style="list-style-type: none"> <li><input type="checkbox"/> LEED®</li> <li><input type="checkbox"/> Green Globes</li> <li><input type="checkbox"/> Other _____</li> </ul> <ul style="list-style-type: none"> <li><input type="checkbox"/> Recycled Content_____</li> <li><input type="checkbox"/> Regional Material_____</li> <li><input type="checkbox"/> Rapidly Renewable Materials</li> <li><input type="checkbox"/> Certified Wood</li> <li><input type="checkbox"/> Low-Emitting Materials</li> <li><input type="checkbox"/> Other_____</li> </ul>
---	--

# GLOSSARY

<b>Astragal</b>	A moulding or trim attached to the meeting edges of adjacent door leaves in order to prevent swing through and to conceal the gap. Also may be used for sound control, bullet resistance and x-ray shielding.
<b>Balanced Match</b>	Two or more veneer components or leaves of equal size (prior to edge trimming) to make up a single face.
<b>Barber Pole</b>	An effect in book matching of veneers. Because the "tight" and "loose" sides alternate in adjacent veneer leaves, they may accept stain or reflect light differently, resulting in a noticeable but acceptable color variation. Barber Pole is not considered a manufacturing defect.
<b>Bark Pocket</b>	Comparatively small area of bark around which normal wood has grown.
<b>Bevel</b>	A machine angle other than a right angle, i.e., a 3 degree bevel that is equivalent to a 1/8 inch drop in a 2 inch span (1 mm in 16mm).
<b>Beveled Edge</b>	An edge of the door which forms an angle of less than 90 degrees with the face of the door, such as a 3 degree beveled edge.
<b>Bird Peck</b>	A mark or wound in a tree or piece of wood caused by birds pecking on the growing tree in search of insects.
<b>Blended Repair Tapering</b>	A repair referring to end splits, repaired with wood or filler similar in color to blend well with adjacent wood.
<b>Blending</b>	Color change that is detectable at a distance of 6 ft. to 8 ft. (1.8 m to 2.4 m) but which does not detract from the overall appearance of the door.
<b>Blister</b>	Spot or area where veneer does not adhere.
<b>Blocking</b>	A material used to replace core material in specific locations to provide improved screw holding for the attachment of hardware. Blocking is only required where the screw holding power of the core is less than required by the applicable performance duty level.
<b>Bonded Core</b>	Stiles and rails (edge bands) are securely glued to the core prior to application of crossbanding, three ply skins, veneers or laminate.
<b>Book Match</b>	Adjacent leaves of veneer from a flitch or log are opened like a book and spliced to make up the face with matching occurring at the spliced joints. The fibers of the wood, slanting in opposite directions in the adjacent leaves, create a characteristic light and dark effect when the surface is seen from an angle.
<b>Book Size</b>	The height and width of a door prior to prefitting.
<b>Bow</b>	A flat wise deviation from a straight line drawn from top to bottom; a curvature along the length of the door.
<b>Brashness</b>	A condition of wood characterized by a low resistance to shock and by abrupt failure across the grain without splintering.
<b>Bullet Resistant Doors</b>	Doors that resist penetration by shots of varying caliber. Resistance may be rated as resistant to medium power, high power, or high power small arms and high power rifles.
<b>Burl</b>	A swirl, twist or distortion in the grain of the wood, which usually occurs near a knot or crotch. A burl can often be associated with abrupt color variation and/or a cluster of adventitious buds.
<b>Burl, Blending</b>	A swirl, twist or distortion in the grain of the wood which usually occurs near a knot or crotch but does not contain a knot and does not contain abrupt color variation.
<b>Butt Joint</b>	A joint formed by square edge surfaces (ends, edges, and faces) coming together; end butt joint, edge butt joint.
<b>Cathedral Grain</b>	A grain appearance characterized by a series of stacked and inverted "V"s, or cathedral type of springwood (earlywood) summerwood (latewood) patterns common in plain sliced (flat cut) veneer (see split heart).
<b>Center Match</b>	An even number of veneer components or leaves of equal size (prior to edge trimming) matched with a joint in the center of the panel to achieve horizontal symmetry.
<b>Certified Wood</b>	Wood products that have been qualified by an independent third party agency as satisfying their proprietary requirements for responsible environmental practices.
<b>Chatter</b>	Line appearing across the face at right angles to the grain giving the appearance of one or more corrugations resulting from bad setting of sanding equipment.
<b>Checks</b>	Small slits running parallel to grain wood, caused chiefly by strains produced in seasoning and drying.
<b>Clustered</b>	When a defect described in the grading rule is sufficient in number and sufficiently close together to appear to be concentrated in one area.
<b>Comb Grain</b>	A quality of rift cut veneer with exceptionally straight grain and closely spaced growth increments resembling the appearance of long stands of combed hair.
<b>Compatible</b>	When relating door edge to face appearance, the edge may not be the same species as the face; however, it may be similar in overall color, grain, character and contrast as the face (See Matching Edge Band).
<b>Component (Of Face Veneer)</b>	An individual piece of veneer or leaf that is joined to other pieces to achieve a full length and width face.

# GLOSSARY

<b>Composite</b>	A composite whose ingredients include cellulosic elements. These cellulosic elements can appear in the form of, but are not limited to: distinct fibers, fiber bundles, particles, wafers, flakes, strands and veneers. These elements may be bonded together with naturally occurring or synthetic polymers. Also, additives such as wax or preservatives may be added to enhance performance.
<b>Conspicuous</b>	See 'burl, conspicuous' and 'knots, conspicuous pin'.
<b>Core</b>	The innermost layer or section in component construction. For typical constructions see: Particleboard Core, Medium Density Fiberboard Core, Structural Composite Lumber Core, Staved Lumber Core, Laminated Veneer Lumber Core, Fire Resistant Composite Core and other special core types.
<b>Core, Fire Resistant</b>	A fire resistant core material generally used in wood doors requiring fire ratings of 3/4 hour or more. Engineered composite products meeting the minimum requirements of WDMA.
<b>Cross Bar (Veneer)</b>	Irregularity of grain resembling a dip in the grain running at right angles, or nearly so, to the length of the veneer.
<b>Cross Break</b>	Separation (break) of the wood cells across the grain. Such breaks may be due to internal strains resulting from unequal longitudinal shrinkage, or to external forces.
<b>Cross Figures</b>	A series of naturally occurring figure effects characterized by mild or dominant patterns across the grain in some faces. For example, a washboard effect occurs in fiddle-back cross figure; and cross wrinkles occur in the mottle figure.
<b>Crossbanding</b>	A ply placed between the core and face veneer in 5-ply construction or a ply placed between the back and face of a 3-ply skin in 7-ply construction, typically of hardwood veneer or engineered wood product.
<b>Cup</b>	A deviation from a straight line drawn from side to side; a curvature along the width of the door.
<b>Dead Knots (Open Knots)</b>	Openings where a portion of the wood knot has dropped out or where cross checks have occurred to present an opening.
<b>Decay</b>	The decomposition of wood substance by fungi.
<b>Defect, Open</b>	Checks, splits, open joints, knotholes, cracks, loose knots, wormholes, gaps, voids, or other opening interrupting the smooth continuity of the wood surface.
<b>Delamination</b>	Separation of plies or layers of wood or other material through failure of the adhesive bond.
<b>Discolorations</b>	Stains in wood substances. Some common veneer stains are sap stains, blue stains, stain produced by chemical action caused by the iron in the cutting knife coming into contact with the tannic acid in the wood, and those resulting from the chemical action of the glue.
<b>Door, Bifold</b>	Doors so hinged as to fold against the door jamb. Bifold doors are normally classified as either two- or four-leaf units.
<b>Door Frame</b>	A group of components (wood, aluminum or steel) that are assembled to form an enclosure and support for a door. Also known as door jambs.
<b>Door, Louver</b>	A door assembly of stiles and rails where the interior is filled with slat or chevron louvers.
<b>Doze</b>	A form of incipient decay characterized by dull and lifeless appearance of the wood, accompanied by a lack of strength and softening of the wood.
<b>Edge Band</b>	A strip along the outside edges of the two sides and/or top and bottom of the door (See stiles/vertical edges, rails/horizontal edges).
<b>End Match</b>	A door/transom combination where single piece of veneer extends from the bottom to the top of the door with a mirror image at the transom.
<b>Engineered Construction</b>	A method of constructing a wood stile and rail door that minimizes the use of solid lumber components. Stiles, rails and mullions have solid lumber edges only (where visible), and have face veneers over a composite core. Panels are also produced using face veneers and/or composite cores.
<b>Engineered Materials</b>	A general term used to describe any wood or plant fiber composite panel. Such products as Particleboard, MDF, SCL and LVL are described as Engineered Fiber. Typically they are made from wood or plant fiber or wood pieces and have specific quality requirements.
<b>Engineered Veneer</b>	Veneers that are first peeled, normally from Obeche or Poplar logs. The peeled veneer leaves are dyed to a specified color, and then glued together in a mold to produce a large laminated block. The shape of the mold determines the final grain configuration. The block is then sliced into leaves of veneer with a designed appearance that is highly repeatable.
<b>Face Veneer</b>	The outermost exposed wood veneer surface of a veneered wood door.
<b>Few</b>	A small number of characteristics without regard to their arrangement in the panel
<b>Fill (Putty Repairs)</b>	A repair to an open defect usually made with fast drying plastic putty. The repairs should be well made with non-shrinking putty of a color matching the surrounding area of the wood, to be flat and level with the face and panel, and to be sanded after application and drying.
<b>Finger Joint</b>	A series of interlocking fingers precision cut on the ends of two pieces of wood which mesh together and are held rigidly in place with adhesive.

# GLOSSARY

<b>Fire Rated Doors</b>	A door which has been constructed in such a manner that when installed in an assembly will pass a fire test under neutral (UL 10B) or positive (UL 10C) pressure criteria and can be rated as resisting fire for 20 minutes (1/3 hour), 45 minutes (3/4 hour), 1 hour, or 1-1/2 hours. The door must be tested and carry an identifying label from a qualified inspection agency.
<b>Fire Resistant Composite Core</b>	A core, typically incorporating minerals rather than wood fiber as the primary component, designed to improve fire resistance and thermal transmission,
<b>Flake</b>	See Fleck, Ray.
<b>Flat-Cut</b>	See Plain-Sliced.
<b>Fleck, Ray (Flake)</b>	Portion of a ray as it appears on the quartered or rift cut surface. Fleck can be dominant appearance in oak and is sometimes referred to as flake.
<b>Flitch</b>	A complete bundle of veneer sheets laid together in sequence as they are cut from a given log or section of log.
<b>Gaps</b>	Open slits in the inner ply or plies or improperly joined veneer when joined veneers are used for inner plies.
<b>Glass Stop</b>	A small wood moulding (bead) applied to the perimeter of glazed openings to secure the glazing materials within a door.
<b>Grain</b>	The direction, size, arrangement and appearance of the fibers in wood or veneer.
<b>Grain Slope</b>	Expression of the angle of the grain to the long edges of the veneer component.
<b>Grain Sweep</b>	Expression of the angle of the grain to the long edges of the veneer component over a 12 inch (300 mm) length from each end of the door.
<b>Gum Pockets</b>	Well-defined opening between rings of annual growth containing gum or evidence of prior gum accumulations. Mainly cherry.
<b>Gum Spots &amp; Streaks</b>	Gum or resinous material of color spots caused by prior resin accumulations sometimes found on panel surfaces.
<b>Hairline</b>	A thin, perceptible line showing at the joint of two pieces of wood.
<b>Half-round</b>	A method of veneer cutting similar to rotary cutting, except that the piece being cut is secured to a "stay log" a device that permits the cutting of the log on a wider sweep than when mounted with its center secured in the lathe to produce rotary sliced veneer. A type of half-round cutting is used to achieve plain-sliced or flat-cut veneer.
<b>Hardboard</b>	Homogeneous panels manufactured primarily from inter-felted lignocellulosic (wood) fibers consolidated under heat and pressure with density of 31 lb/ft <sup>3</sup> (497 kg/m <sup>3</sup> ) or more.
<b>Hardwood</b>	General term used to designate lumber or veneer produced from temperate zone deciduous or tropical broad-leaved trees in contrast to softwood, which is produced from trees which are usually needle bearing or coniferous. The term does not infer hardness in its physical sense.
<b>Heartwood</b>	The non-active center of a tree generally distinguishable from the outer portion (sapwood) by its darker color.
<b>High Pressure Decorative Laminate</b>	A high impact resistant surface material consisting of decorative surface paper impregnated with melamine resins pressed over multiple craft paper layers saturated with phenolic resins, thermoset at high pressure and temperature.
<b>High Density Fiberboard (HDF)</b>	No longer defined under ANSI A208.2; HDF is a marketing term to define MDF grades above Grade 150
<b>Holes, Worm</b>	Holes resulting from infestation by worms greater than 1/16 inch (1.6 mm) in diameter and not exceeding 5/8 inch (16 mm) in length.
<b>Inconspicuous</b>	Barely detectable with the naked eye at a distance of 6 ft. to 8 ft. (1.8 m to 2.4 m).
<b>Indentations</b>	Areas in the face that have been compressed as the result of residue on the platens of the hot press or handling damages.
<b>Intumescent</b>	A material that expands when exposed to extreme heat or fire to fill any gap between the door and frame or between doors.
<b>Joint</b>	The line of juncture between the edges or ends of two adjacent pieces of veneer.
<b>Joint, Edge</b>	Joint running parallel to the grain of the wood.
<b>Joint, Open</b>	Joint in which two adjacent pieces of veneer do not fit tightly together.
<b>Kiln-Dried</b>	Lumber dried in a closed chamber in which the removal of moisture is controlled by artificial heat and usually by controlled relative humidity.
<b>Knife Cuts per inch (KCPI)</b>	A measure of the smoothness of machined lumber. Can be determined by holding the surfaced board at an angle to a strong light source and counting the visible ridges per inch, usually perpendicular to the profile. The surface is smoother with more knife marks per inch.
<b>Knife Marks</b>	Very fine lines that appear across the panel veneer or wood solids that can look as though they are raised resulting from some defect in the lathe knife that cannot be removed with sanding.
<b>Knot</b>	Cross section of tree branch or limb with grain usually running at right angles to that of the piece of wood in which it occurs.
<b>Knot Holes</b>	Voids produced when knots drop from the wood in which they were originally embedded.



# GLOSSARY

<b>Knots, Blending Pin</b>	Sound knots 1/4 inch (6.4 mm) or less that generally do not contain dark centers. Blending pin knots are barely detectable at a distance of 6 ft. to 8 ft. (1.8 m to 2.4 m), do not detract from the overall appearance of the panel, and are not prohibited from appearing in all grades.
<b>Knots, Conspicuous Pin</b>	Sound knots 1/4 inch (6.4 mm) or less in diameter containing dark centers.
<b>Knots, Open (Knot Holes)</b>	Openings where a portion of the wood substance of the knot was dropped out, or where cross checks have occurred to produce an opening.
<b>Knots, Sound Tight</b>	Knots that are solid across their face and fixed by growth to retain their place.
<b>Laminated Veneer Lumber Core (LVLC)</b>	Manufactured by laminating veneer with all grain laid-up parallel. It can be manufactured by using various species of wood fiber in various thicknesses.
<b>Lap (Veneer)</b>	A condition where the pieces of veneer are so misplaced that one piece overlaps the other and does not make a smooth joint.
<b>Lock Block</b>	A concealed block the same thickness as the door stile or core which is adjacent to the stile at a location corresponding to the lock location and into which a lock is fitted.
<b>Loose Side</b>	In knife-cut veneer, that side of the sheet that was in contact with the knife as the veneer was being cut, and containing cutting checks (lathe checks) because of the bending of the wood at the knife edge.
<b>Low Pressure Decorative Laminate</b>	A decorative surface paper that is saturated with reactive resins. During hot press lamination, the resin flows into the surface of the substrate, creating a hard crosslinked thermosetting permanent bond and permanently changing the characteristics of both the paper and the board.
<b>Louver</b>	A panel constructed of wood or metal slats installed in an opening to allow light, air and noise. Common types are slat and Chevron – an inverted “V” wood louver (vented or non-vented).
<b>Matching Edge Band (ME)</b>	An edge band that is the same species or laminate pattern as the face veneer.
<b>Medium Density Fiberboard (MDF)</b>	The generic name for a panel or core manufactured from lignocellulosic fibers combined with a synthetic resin or other suitable binder and bonded together under heat and pressure in a hot press by a process in which the added binder creates the entire bond.
<b>Medium Density Overlay (MDO)</b>	Typically MDO is kraft paper saturated with resin and cured under high heat and pressure to make a hard, smooth, paintable surface.
<b>Medium Density Fiberboard Core (MDFC)</b>	Wood fiber and/or agri-fiber based materials that comply with ANSI A208.2.
<b>Meeting Edges</b>	Two adjacent door edges not separated by a mullion or transom bar. These are found in pair, Dutch door and door & transom applications.
<b>Mineral</b>	See Streaks, Mineral.
<b>Mineral Core</b>	See Core, Fire Resistant.
<b>Mineral Stain</b>	Olive and greenish-black streaks believed to designate areas of abnormal concentration of mineral matter; common in hard maple, hickory, and basswood. Also called Mineral Streak.
<b>Mineral Streaks</b>	Sharply contrasting elongated discoloration of the wood substance.
<b>Natural</b>	When referring to color and matching, veneers containing any amount of sapwood and/or heartwood, i.e., natural birch, maple, ash.
<b>Neutral Pressure</b>	A fire door test procedure where the neutral pressure plane is near the top of the door.
<b>Nominal</b>	A term that designates a stated dimension as being approximate and subject to allowances for variation.
<b>Non-Bonded Core</b>	Stiles and rails (edge bands) are not glued to the core prior to face materials.
<b>Not Restricted</b>	Allowed, unlimited.
<b>Occasional</b>	A small number of characteristics that are arranged somewhat diversely within the face.
<b>Particleboard</b>	A panel or core product composed of small particles of wood and wood fiber that are bonded together with synthetic resin adhesives in the presence of heat and pressure.
<b>Particleboard Core</b>	Wood fiber and/or agri-fiber based materials that comply with ANSI A208.1, minimum grade LD-1.
<b>Patches</b>	Matching wood pieces carefully inserted and glued into the door face after defective portions have been removed.
<b>Plain Sliced</b>	Veneer sliced parallel to the pith of the log and approximately tangent to the growth rings to achieve flat cut veneer. Plain sliced veneer can be cut using either a horizontal or vertical slicing machine or by the half-round method using a rotary lathe. Also known as flat cut
<b>Plank Matched</b>	A face containing specially selected and assembled dissimilar (in color, grain and width) veneer strips of the same species, and sometimes grooved at the joints between strips, to simulate lumber planking. Plank matched faces are not available pair matched or set matched.
<b>Pleasing Match</b>	A face containing components, which provide a pleasing overall appearance. The grain of the various components need not be matched at the joints. Sharp color contrasts at the joints of the components are not permitted.

# GLOSSARY

<b>Ply</b>	A single sheet of veneer or several strips laid with adjoining edges that may or may not be glued, which forms one veneer lamination in a glued panel. In some constructions, a ply is used to refer to other wood components such as particleboard or MDF.
<b>Positive Pressure</b>	A fire door test procedure where the neutral pressure plane is located at 40 inches (1 m) above the sill.
<b>Prefitting</b>	Trimming of the door for width and/or height.
<b>Puttied</b>	See Fill.
<b>Quartered (Quarter-sliced, Quarter Cut)</b>	Veneer produced by cutting in a radial direction to the pith to achieve a straight (vertical) grain pattern. In some species, principally red oak and white oak, ray fleck is produced, the amount of which may be unlimited.
<b>Ray</b>	Ribbon-shaped strand of tissue extending in a radial direction across the grain, so oriented that the face of the ribbon is exposed as a fleck on the quarter surface. Also known as Wood Ray
<b>Rails/Horizontal Edges</b>	Top and bottom edge bands of door.
<b>Random Matched (Mismatched)</b>	A face containing veneer strips of the same species which are selected and assembled without regard to color or grain, resulting in variations, contrasts and patterns of color and grain. Pleasing appearance is not required. Random matched faces are not available pair matched or set matched.
<b>Ray Fleck</b>	See Fleck, Ray.
<b>Red/Brown</b>	When referring to color and matching, veneers containing all heartwood, ranging in color from light to dark.
<b>Repairs</b>	A patch, shim, or filler material inserted and/or glued into veneer or a panel to achieve a sound surface.
<b>Repairs, Blending</b>	Wood or filler insertions similar in color to adjacent wood so as to blend well.
<b>Rift Cut</b>	Veneer produced by cutting at a slight right angle to the radial to produce a parallel grain pattern and quartered appearance without excessive ray fleck. Oak veneer only.
<b>Rotary Cut</b>	Veneer produced by centering the entire log in a lathe and turning it against a broad cutting knife.
<b>Rough Cut</b>	Irregular shaped areas of generally uneven corrugation on the surface of veneer.
<b>Running Match</b>	The veneer face is made from components running through the flitch consecutively. Any portion of the component left over from a face is used as the beginning component or leaf in starting the next veneer face.
<b>Ruptured Grain</b>	A break or breaks in the grain or between springwood and summerwood caused or aggravated by excessive pressure on the wood by seasoning, manufacturing, or natural processes. Ruptured grain appears as a single or series of distinct separations in the wood such as when springwood is crushed leaving the summerwood to separate in one or more growth increments.
<b>Rustic</b>	Lacking excessive refinement, having a rough surface or finish.
<b>Safety Glazing Materials</b>	Glazing materials so constructed, treated or combined with other material as to minimize the likelihood of cutting or piercing injuries resulting from human contact with the material. The most common types used in doors are tempered or laminated. Safety glazing materials are required to meet codes and federal regulations.
<b>Sanding (Chatter, Dust, Burns)</b>	The degree of defects allowed in sanding of the face.
<b>Sapwood</b>	The living wood of lighter color occurring in the outer portion of a tree.
<b>Shake</b>	A separation along the grain of wood in which the greater part occurs between the rings of annual growth.
<b>Sharp Contrast</b>	For the purpose of this standard, this term means the veneer of lighter than average color should not be joined at the edges with veneer of darker than average color, and that two adjacent pieces of veneer should not be widely dissimilar in grain, figure and natural character markings.
<b>Shims</b>	A split repaired in a piece of wood veneer, preferably from the same piece of veneer from which the face is made to ensure good color and grain match. The grain running in the same direction as the split to be inconspicuous to the naked eye, and free of any gaps where the shim joins the veneer. To be glued into the split and sanded after being made. Color matched.
<b>Show Through (Telegraphing)</b>	A defect caused by the outline and/or surface irregularities, such as frame parts, core laps, voids, etc., that is visible through the face veneers.
<b>Skin</b>	The face layer of a flush or stile and rail door, whether flat or configured, which is used for facings for flush wood doors.
<b>Sliced</b>	Veneer produced by thrusting a log or sawed flitch into a slicing machine, which shears off veneer in sheets.
<b>Slight</b>	Visible on observation, but does not interfere with the overall aesthetic appearance.
<b>Slip Matched</b>	A sheet from a flitch is slid across the sheet beneath and, without turning, spliced at the joint.
<b>Slope</b>	See grain
<b>Smooth, Tight Cut</b>	Veneer cut to minimize lathe checks.
<b>Sound Transmission Class (STC)</b>	A single number rating system derived from measured values of sound transmission loss or the acoustical performance of a building element, such as a door, window or wall. The higher the STC value, the better the rating and the better the acoustical performance value. Tested in accordance with ASTM E413 and E90.

# GLOSSARY

<b>Split Heart</b>	A method of achieving an inverted "V" or cathedral type of springwood (earlywood)/summerwood (latewood), plain-sliced (flat-cut) figure by joining two veneer components of similar color and grain. A cathedral type figure must be achieved by a single component in AA grade; the split heart method is allowed in grades A and B. Each half of a split heart shall be subject to the minimum component width requirements for grade A and B faces.
<b>Splits</b>	Separations of wood fiber running parallel to the grain.
<b>Splits, Hairline</b>	A perceptible separation or absence of wood fiber running parallel with the grain.
<b>Standard Door</b>	By industry practice, a standard door is book size in both width and height.
<b>Staved Lumber Core (SLC)</b>	Made with any combination of blocks or strips of wood, not more than 2-1/2 inches (64 mm) wide, of one species of wood glued together (in butcher block fashion), with joints staggered in adjacent rows.
<b>Stiles/Vertical Edges</b>	The upright or vertical pieces of the core assembly of a wood flush door. Measurement. The width of the vertical edge/stile is measured at its widest side (the wide side of a beveled door).
<b>Streaks, Mineral</b>	Sharply contrasting elongated discoloration of the wood substance.
<b>Structural Composite Lumber Core (SCLC)</b>	An engineered wood product that is made by fusing a network of wood strands together with a water-resistant adhesive to produce a strong, solid and stable product that has true structural properties with excellent screw holding properties and very high split resistance.
<b>Sugar</b>	See Worm Tracks.
<b>Sweep</b>	See Grain
<b>Tape</b>	Strips of gummed paper used to hold the edges of the veneer together at the joints prior to gluing.
<b>Telegraphing</b>	See Show Through.
<b>Tight Side</b>	In knife-cut veneer, that side of the sheet that was farthest from the knife as the sheet was being cut and containing no cutting checks (lathe checks).
<b>Transom</b>	The panel above a door or set of doors.
<b>Twist</b>	A deviation in which one or two corners of the door are out of plane with the other corners of the door.
<b>Veneer (wood)</b>	A thin sheet of wood, rotary cut, sliced, or sawed from a log, bolt, or flitch.
<b>Veneered Construction</b>	See Engineered Construction
<b>Vine Streaks (Mark.)</b>	Scars in the wood generally caused by the stems of clinging vines or by their hair-like roots, which cling to the tree trunk. Live vine streaks produce round scars. Dead vine streaks contain either dead residue of the vine, or the remaining pocket similar to bark pocket. Most vine streaks run across the grain, and therefore, all vine streaks are considered defects in accordance with restrictions described in veneer grading rules.
<b>Voids</b>	See Gaps.
<b>Warp</b>	Any distortion in the plane of a door itself and not its relationship to the frame or jamb in which it is to be hung. The term warp includes bow, cup and twist, which are defined as follows: Bow-A flat wise deviation from a straight line drawn from top to bottom; a curvature along the length of the door. Cup-A deviation from a straight line drawn from side to side; a curvature along the width of the door. Twist-A deviation in which one or two corners of the door are out of plane with the other corners of the door.
<b>White</b>	When referring to color and matching, veneers containing all sapwood, ranging in color from pink to yellow.
<b>Wood Filler</b>	An aggregate of resin and strands, shreds, or flour of wood, which is used to fill openings in wood and provide a smooth, durable surface.
<b>Wood Flush Door</b>	An assembly consisting of a core and one or more edge bands, with 2 plies of wood veneer with laminate, wood, or wood derivative on each side. All parts are composed of wood, wood derivatives, fire resistant composites or decorative laminates.
<b>Worm Track (Scar)</b>	Marks caused by various types of wood attacking larvae. Often appear as sound discolorations running with or across the grain in straight to wavy streaks. Sometimes referred to as 'pith flecks' in certain species of maple, birch and other hardwoods because of a resemblance to the color of pith.

# AESTHETICS

## A-1: Aesthetic Grades for Architectural Wood Flush Doors

The design professional can specify with confidence using WDMA I.S.1A guidelines. WDMA's Architectural Wood Flush Door Standard addresses both the aesthetic and performance attributes of the door. Both are important to achieve desired appearance and function.

Wood flush door aesthetics are specified by choosing a Premium grade or Custom grade door. These designations determine the basic appearance of the door with respect to veneer grade, matching requirements, pair and set matching, vertical edge species and other attributes that determine the appearance in individual doors and doors in pairs.

<b>Premium</b>	The highest grade commercially available in both material and fabrication. This grade is intended for the finest commercial, industrial and institutional buildings. Uses AA grade faces that are assembled using book and center balance match; other face options are available but must be specified.
<b>Custom</b>	The standard grade in both material and fabrication. This grade is intended for high-quality work. Uses A Grade faces that are assembled using book and running match; other face options are available but must be specified.
Note: If the Aesthetic Grade is not specified, Custom grade is the default.	
Note: Economy grade has been discontinued as it is seldom specified for architectural wood flush doors.	

It is also possible for a specifier to alter the basic premium grade or custom grade requirements to either upgrade or downgrade certain aspects of the door appearance, such as:

Special Flitch Selection  
Sketch Faces  
Special Veneer Matches  
Minimum Veneer Piece Width

Special Color Ranges (face and/or edge)  
Faces Other Than Wood Veneer  
Finer Finishes

There are other ways to modify the aesthetics of the door as well, such as by the addition of applied mouldings, lite mouldings, louvers and other appurtenances.

The design professional is encouraged to consult directly with the manufacturer during the development of the design and specifications for these important projects.

## A-2: Face Selection

Specifiers need to determine and specify the door face material required.

### Veneers for Transparent Finishes

#### Premium Grade Doors:

Grade AA faces, book and center balance match, are standard for Premium grade doors. Face veneer shall be of sufficient thickness so as not to permit show through of crossbanding after sanding and/or before finishing. Other face options are available but must be specified.

#### Custom Grade Doors:

Grade A faces, book and running match, are standard for Custom grade doors. Face veneer shall be of sufficient thickness so as not to permit show through of crossbanding after sanding and/or before finishing. Other face options are available but must be specified.

Species: There are numerous domestic and foreign wood species available from which to select veneer type, including those further defined in Section A-8.

Matching: Many different visual effects can be obtained by face veneer matching. The various considerations in matching are described in the following sections:

- A-3: Appearance of Individual Pieces of Face Veneer.
- A-4: Matching Between Individual Face Veneer Pieces.
- A-5: Assembly of Spliced Face Veneer on a Door Face.
- A-6: Appearance of Doors in Pairs or Sets.
- A-7: Appearance of Doors with Transoms

## Materials for Opaque Finishes

### Premium Grade Doors:

Medium Density Overlay (MDO), Medium Density Fiberboard (MDF), or hardboard. This surface provides the optimum finishing surface for Premium grade doors. The overlay is designed to take and hold finish.

### Custom Grade Doors:

Closed grain hardwood veneer, Medium Density Overlay (MDO), Medium Density Fiberboard (MDF), hardboard, or other composite materials. When using hardwood veneer, extra preparation is required prior to job site finishing because of the natural characteristics of wood. Crossbands are not required under hardboard or composite surfaces.

## Laminates

High Pressure Decorative Laminates (HPDL): Virtually any high pressure laminate color and texture can be utilized in the manufacture of architectural wood flush doors. However, high gloss laminates should be avoided because they tend to accentuate natural telegraphing.

Low Pressure Decorative Laminates (LPDL) or Thermally Fused Paper: A laminate in which the resin flows into the surface of the substrate during lamination, creating a permanent bond and a low gloss finish. Many colors and patterns are available.

## Other Materials

Manufacturers offer a variety of other face options for doors, including but not limited to polyvinyl chloride (PVC), fiberglass reinforced plastic (FRP), cork and leather. Consult with a specific manufacturer for their specific offerings.

## A-3: Appearance of Individual Veneer Leaves

The beauty of veneer is in the natural variations of texture, grain, figure, color, and the way it is assembled on a door face. The way in which a log is cut, in relation to the annual growth rings, determines the appearance of veneer. The illustrations above represent a typical appearance produced with the different types of cut. However, veneers leaves will have natural variations in grain and pattern that are inherent in the species and cut.

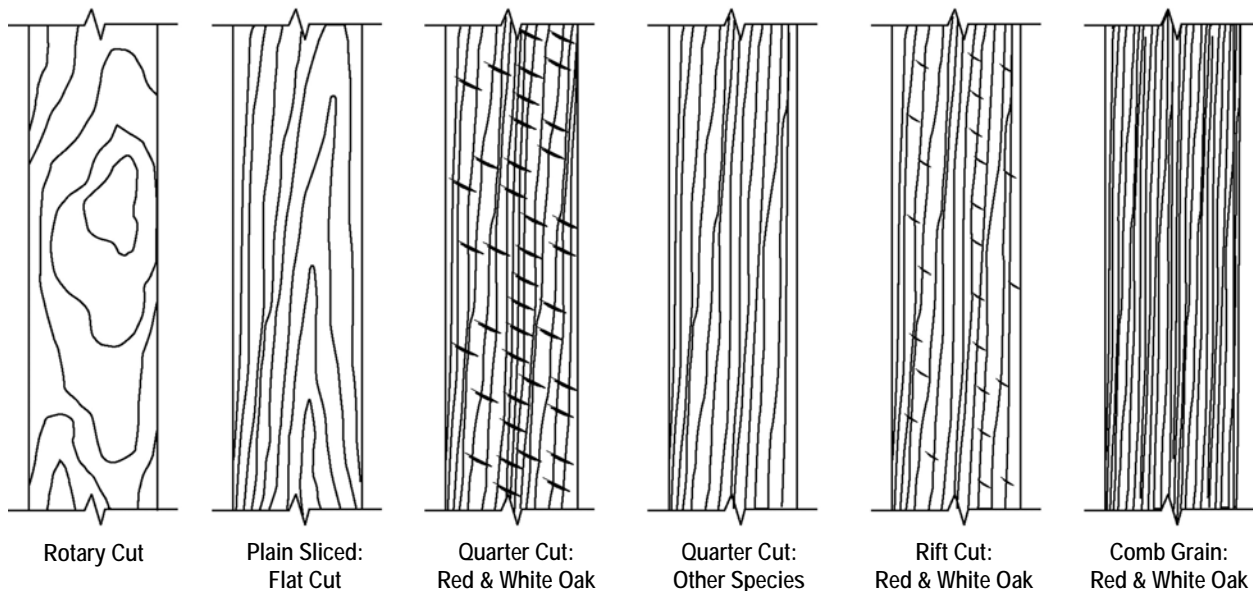

### Rotary

This cut follows the log's annual growth rings, providing a generally bold random appearance.

### Plain Sliced (Flat Cut)

Slicing is done parallel to a line through the center of the log, resulting in cathedral and straight grained patterns. The individual pieces of veneer are kept in the order they are sliced, permitting a natural grain progression when assembled as veneer faces.

### Quarter Cut

By slicing the log roughly parallel to a radius line through the log segment, a series of stripe is produced that vary in width from species to species. Ray fleck (flake) is a characteristic of this cut in Red and White Oak.

### Rift Cut (only in Red & White Oak)

This cut slices slightly across the medullary rays, accentuating the vertical grain and minimizing the ray fleck (flake). Rift grain is restricted to Red and White Oak.

### Comb Grain (limited availability) (only in Red & White Oak)

This is a rift cut veneer distinguished by the tightness and straightness of the grain along the entire length of the veneer. Slight angle in the grain is allowed. Comb grain is restricted to Red and White Oak. There are occasional cross bars, and ray fleck (flake) is minimal.

## A-4: Matching Between Individual Veneer Leaves

The ways by which veneer leaves can be pieced together create a variety of looks for the assembled veneer. The type of match must be specified; if not specified, book match will be provided.

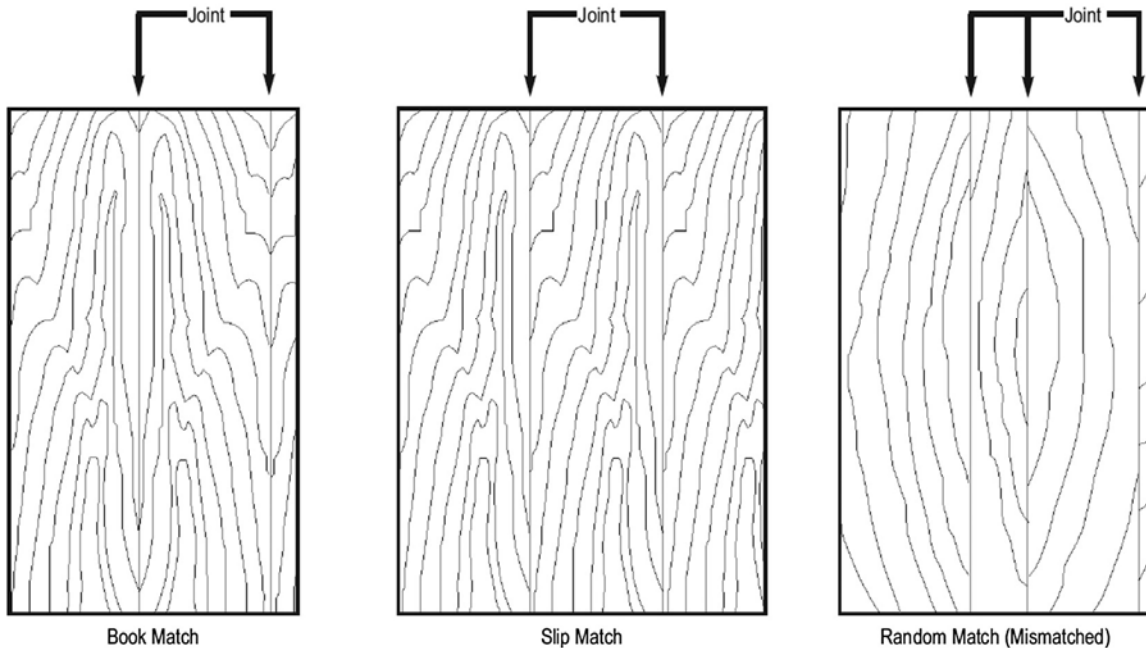

Illustrations reprinted with permission from, Architectural Woodwork Institute, Reston, Virginia

### Book Match

The most commonly used match in the industry, every other piece of veneer is turned over so adjacent pieces are like two adjacent pages in an open book. The veneer joints match and create a mirrored image pattern at the joint line, yielding a maximum continuity of grain. Book matching is used with Rotary, Plain Sliced, Quarter, Rift Cut or Comb Grain veneers.

#### Barber Pole Effect in Book Match

Because the "tight" and "loose" sides alternate in adjacent pieces of veneer that are book matched, the leaves may accept stain or reflect light differently, which may cause a noticeable color variation called barber poling. See slip match for further information on color variation. Barber pole is not considered a manufacturing defect.

### Slip Match

Adjoining pieces of veneer are placed in sequence without turning over every other piece. The grain figure repeats, but joints won't have a mirrored effect. Slip matching is recommended and often used in Quarter, Rift Cut and Comb Grain veneers to eliminate the barber pole effect. However, it may cause a sloping appearance of the veneer, especially in taller doors.

### Random Matched (Mismatched – not commonly used for doors)

A face containing veneer leaves of the same species which are selected and assembled without regard to color or grain, resulting in variations, contrasts and patterns of color and grain. Pleasing appearance is not required. Random matched faces are not available pair matched or set matched.

### Plank Matched (not illustrated)

A face containing specially selected and assembled veneer leaves from a single species. The leaves are dissimilar (in color, grain and width) veneer strips of the same species, and sometimes grooved at the joints between strips, to simulate lumber planking. Plank matched faces are not available pair matched or set matched.

## A-5: Assembly of Spliced Veneer Leaves on Door Face

The way matched veneer leaves are assembled within a given door face can also help achieve a desired look. The type of assembly match must be specified. If no specification is made, Running Match is the default.

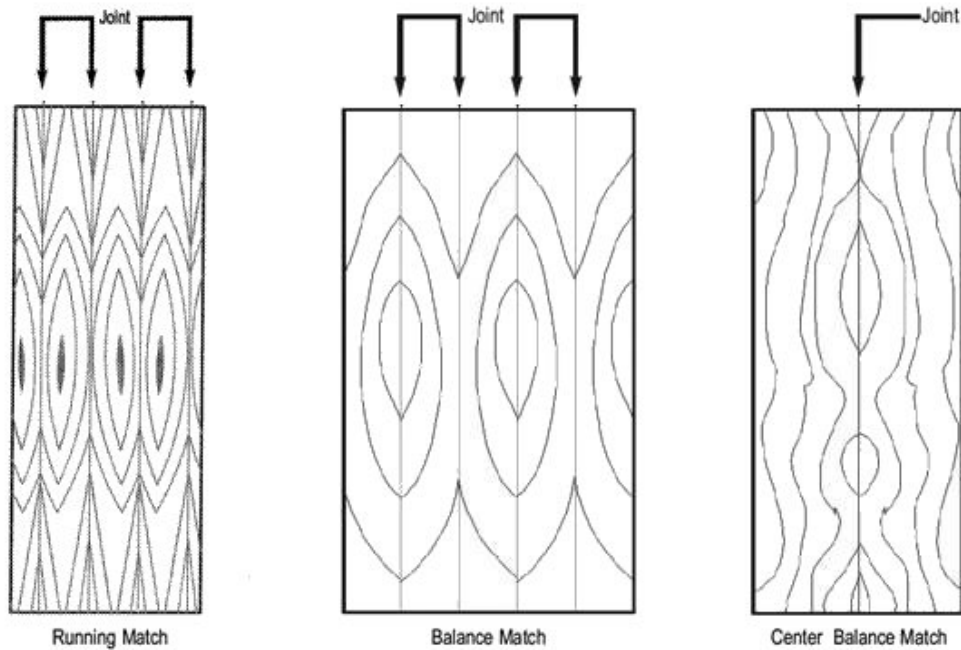

Illustrations reprinted with permission from the Architectural Woodwork Institute, Reston, Virginia

### Running Match

Each face is assembled from as many veneer leaves as necessary. The inside leaves will be equal in width to one another, the outside veneer leaves will be of unequal width. This provides a non-symmetrical appearance in each door face and results in high yield.

### Balance Match

Each face is assembled from leaves of uniform width before trimming, resulting in a symmetrical appearance and medium yield.

### Center Balance Match

Each face is assembled from an even number of veneer leaves of uniform width before trimming. Thus there is a veneer joint in the center of the panel, producing symmetry but resulting in low yield.

## A-6: Appearance of Doors in Pairs or Sets

When a specific transition is desired between paired doors or sets of doors within a space, it is important to specify the requirement accordingly.

The illustrations below show faces constructed using the Center Match process. Pairs and sets may also be manufactured with Running Match or Balance Match faces. Any sequence matching required from opening to opening must be specified.

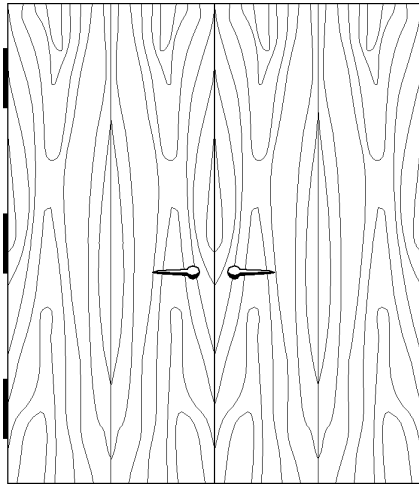

Pair Match

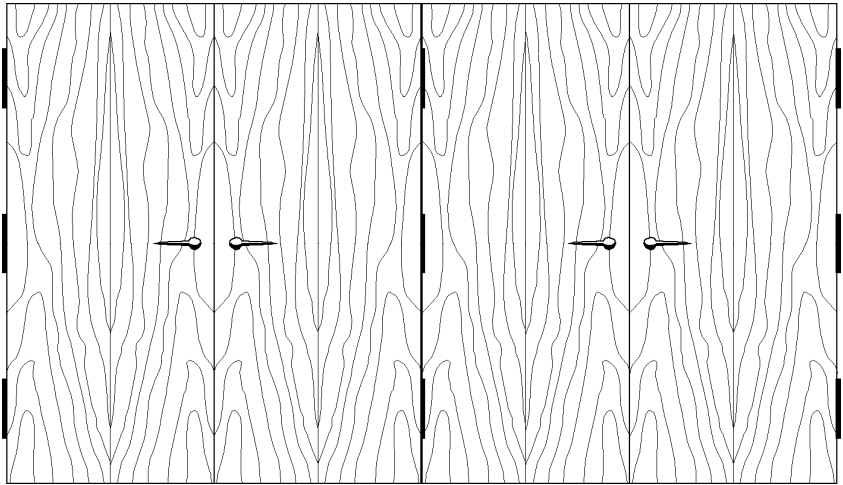

Set Match

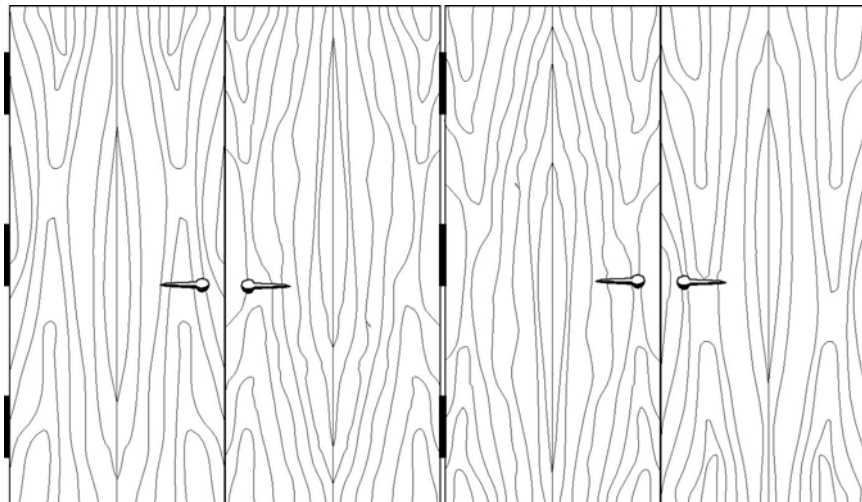

Running Match

Illustrations reprinted with permission from the Architectural Woodwork Institute, Reston, Virginia

**Note:**

The type of match must be specified. If no specification is made, running match is the most commonly used assembly method for A grade faces. Any sequence matching from opening to opening must be specified.

### Pair Match

Doors hung in adjacent sets or in close proximity where the veneer on one leaf is either Center, Book or Balance Matched to the other leaf in the pair.

### Set Match

Pair matching doors in groups or multiples (i.e., pair matching of pairs).



## A-7: Appearance of Doors with Transoms

When specifying doors with adjacent transoms, the match between the door and transom must be specified,

Premium	Bottom Edge: Full width, veneered or solid, same species as door face.
Custom	Bottom Edge: Full width, veneered or solid, compatible species to door face.

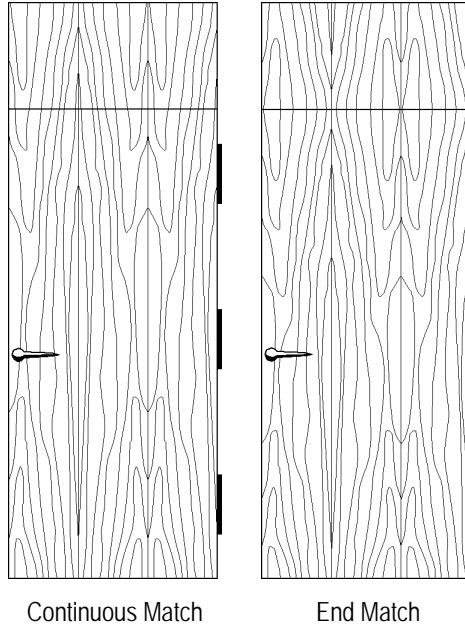

Illustrations reprinted with permission from the 8th Architectural Woodwork Institute, Reston, Virginia

### Continuous Match

Veneer extends from the bottom of the door to the top of the transom. Veneer length may limit this option.

### End Match

Veneer extends from the bottom of the door to the top of the door with a mirror image at the transom.

With any of these door/transom match types, slight misalignment of veneer grain may occur at the transition from door to transom. A variation of grain alignment from side to side is acceptable for transom matching as follows:

Single door and transom: 3/8 inch (9.5mm)

Pair of doors with single transom: 1/2 inch (12.7mm)

## A-8: Flush Door Face Veneer Characteristics

The following tables identify the guidelines used to determine acceptable characteristics for a variety of wood species with respect to grades AA and A. If doors are intended to be installed adjacent to or are intended to become part of other architectural woodwork, veneer criteria shall conform to HPVA veneer panel grades.

## DOOR FACE DESCRIPTION - Ash, Beech, Birch, Maple and Poplar

(Adapted from HPVA with permission) WHEN SPECIFYING NATURAL, VENEERS CONTAIN UNLIMITED AMOUNTS OF SAPWOOD AND/OR HEARTWOOD

Cut	Plain-Sliced (Flat Cut) and Quarter Cut					
Grade Description	AA			A		
<b>Color and Matching</b>						
	Sap (White)	Heart (Red/Brown)	Natural	Sap (White)	Heart (Red/Brown)	Natural
Sapwood	Yes	No	Yes	Yes	No	Yes
Heartwood	No	Yes	Yes	No	Yes	Yes
Color Streaks or Spots	Slight			Slight	Yes	
Color Variation	Slight	Yes		Slight	Yes	
Sharp Color Contrasts at Splice Joints	Yes, if Slip, Plank or Random matched			Yes, if Slip, Plank or Random matched		
<b>Type Of Matching</b>						
Book Matched	Yes			Yes		
Slip Matched	Specify			Specify		
Pleasant Matched	not applicable			not applicable		
Nominal Minimum Plain Sliced Width of Leaves (a) Quarter Rotary	5 inches (127 mm) 3 inches (76 mm) 5 inches (127 mm)			4 inches (102 mm) 3 inches (76 mm) 4 inches (102 mm)		
<b>Natural Characteristics (except as listed below, natural characteristics are not restricted)</b>						
Small Conspicuous Burls & Pin Knots-Combined Avg. Number	1 per 5 sq. ft. (2 per sq. m)			1 per 3 sq. ft. (4 per sq. m)		
Conspicuous Burls - Max. Size	1/4 inch (6.4 mm)			3/8 inch (9.5 mm)		
Conspicuous Pin Knots Avg. Number Max. Size: Dark Part Total	No			1 per 8 sq. ft. (4 per 3 sq. m) 1/8 inch (3.2 mm) 1/4 inch (6.4 mm)		
Scattered Sound and Repaired Knots - Combined Avg. No. Max. Size - Sound Max. Size - Repaired Avg. No. - Repaired	No			No		
Mineral Streaks	No; Maple, slight			Slight		
Bark Pockets	No			No		
Worm Tracks	Slight			Slight		
Vine Marks	Slight			Slight		
Cross Bars	Slight			Slight		
<b>Manufacturing Characteristics</b>						
Rough Cut / Ruptured Grain	No			No		
Blended Repaired Tapering Hairline Splits	Two 1/32 inch x 3 inch (Two 0.8 mm x 76 mm) (on ends only)			Two 1/16 inch x 6 inch (Two 1.6 mm x 152 mm)		
Repairs	Very Small Blending			Small Blending		
<b>Special Characteristics (except as listed below, special characteristics are not restricted)</b>						
Quarter Cut	1 inch in 12 inches (25.4 mm in 305 mm) maximum grain slope, 2 1/2 inches in 12 inches (63.5 mm in 305 mm) maximum grain sweep					

Unfilled worm holes, open splits, open joints, open bark pockets, shake or doze not allowed in above grades.

- Notes: a. Outside components will be a different size to allow for edge trim loss and certain types of matching.  
b. American or European

## DOOR FACE DESCRIPTION - African and Honduras Mahogany, Anegre, Makore, Sapele

(Adapted from HPVA with permission)

Cut	Plain-Sliced (Flat-Cut) and Quarter-Cut	
Grade Description	AA	A
<b>Color and Matching</b>		
Sapwood	No	No
Heartwood	Yes	Yes
Color Streaks or Spots	Slight	Slight
Color Variation	Slight	Slight
Sharp Color Contrasts at Splice Joints	Yes, if Slip, Plank or Random matched	Yes, if Slip, Plank or Random matched
<b>Type Of Matching</b>		
Book Matched	Yes	Yes
Slip Matched	Specify	Specify
Plearing Matched	not applicable	not applicable
Nominal Minimum Plain Sliced	5 inches (127 mm)	4 inches (102 mm)
Width of Leaves (a) Quarter	3 inches (76 mm)	3 inches (76 mm)
Rotary	5 inches (127 mm)	4 inches (102 mm)
<b>Natural Characteristics (except as limited below, natural characteristics are not restricted)</b>		
Small Conspicuous Burls & Pin Knots-Combined Avg. Number	1 per 5 sq. ft. (2 per sq. m)	1 per 3 sq. ft. (4 per sq. m)
Conspicuous Burls - Max. Size	1/4 inch (6.4 mm)	3/8 inch (9.5 mm)
Conspicuous Pin Knots		
Avg. Number	No	1 per 8 ft. sq. (4 per 3 sq. m)
Max. Size: Dark Part		1/8 inch (3.2 mm)
Total		1/4 inch (6.4 mm)
Scattered Sound and Repaired Knots - Combined Avg. No.	No	No
Max. Size - Sound		
Max. Size - Repaired		
Avg. No. - Repaired		
Mineral Streaks	No	Slight
Bark Pockets	No	No
Worm Tracks	No	No
Vine Marks	Slight	Slight
Cross Bars	Occasional	Occasional
<b>Manufacturing Characteristics</b>		
Rough Cut / Ruptured Grain	No	No
Blended Repaired Tapering Hairline Splits	Two 1/32 inch x 3 inch (Two 0.8 mm x 76 mm) (on ends only)	Two 1/16 inch x 6 inch (Two 1.6 mm x 152 mm)
Repairs	Very Small Blending	Small Blending
<b>Special Characteristics (except as limited below, special characteristics are not restricted)</b>		
Quarter Cut	1 inch in 12 inches (25.4mm in 305 mm) maximum grain slope, 2-1/2 inches in 12 inches (63.4 mm in 305 mm) maximum grain sweep	

Unfilled worm holes, open splits, open joints, open bark pockets, shake or doze not allowed in above grades.

Note: a. Outside components will be a different size to allow for edge trim loss and certain types of matching.

## DOOR FACE DESCRIPTION - Red and White Oak

(Adapted from HPVA with permission)

Cut	Plain-Sliced (Flat Cut), Quarter Cut and Rift and Comb Grain			
Grade Description	AA		A	
	Red Oak	White Oak	Red Oak	White Oak
<b>Color and Matching</b>				
Sapwood	No	No	5% (a)	5% (a)
Heartwood	Yes	Yes	Yes	Yes
Color Streaks or Spots	Yes		Yes	
Color Variation	Slight		Slight	
Sharp Color Contrasts at Splice Joints	Yes, if Slip, Plank or Random matched		Yes, if Slip, Plank or Random matched	
<b>Type of Matching</b>				
Book Matched	Yes		Yes	
Slip Matched	Specify		Specify	
Pleasing Matched	not applicable		not applicable	
Nominal Minimum Plain Sliced	5 inches (127 mm)		4 inches (102 mm)	
Width of Leaves (c) Quarter/Rift	3 inches (76 mm)		3 inches (76 mm)	
Rotary	5 inches (127 mm)		4 inches (102 mm)	
<b>Natural Characteristics (except as limited below, natural characteristics are not restricted)</b>				
Small Conspicuous Burls & Pin Knots-Combined Avg. Number	1 per 4 sq. ft. (3 per sq. m)		1 per 2-2/3 sq. ft. (4 per sq. m)	
Conspicuous Burls - Max. Size	1/4 inch (6.4 mm)		3/8 inch (9.5 mm)	
Conspicuous Pin Knots				
Avg. Number	No		1 per 3 sq. ft. (4 per sq. m)	
Max. Size: Dark Part			1/8 inch (3.2 mm)	
Total			1/4 inch (6.4 mm)	
Scattered Sound and Repaired Knots - Combined Avg. No.				
Max. Size - Sound	No		No	
Max. Size - Repaired				
Avg. No. - Repaired				
Mineral Streaks	No		Slight, Blending	
Bark Pockets	No		No	
Worm Tracks	No		No	
Vine Marks	No		Slight	
Cross Bars	Slight		Slight	
<b>Manufacturing Characteristics</b>				
Rough Cut / Ruptured Grain	No		No	
Blended Repaired Tapering Hairline Splits	Two 1/32 inch x 3 inch (Two 0.8 mm x 76 mm) (on ends only)		Two 1/16 inch x 6 inch (Two 1.6 mm x 152 mm)	
Repairs	Very Small Blending		Small Blending	
<b>Special Characteristics (except as limited below, special characteristics are not restricted)</b>				
Ray Fleck (Flake)	Slight, Blending Quarter cut unlimited		Slight, Blending Quarter cut unlimited	
	Rift not to exceed 3/8 inch (9.5 mm) in width			
	Comb not to exceed 3/32 inch (2.4 mm) in width			
Slope and Sweep <i>Quarter &amp; Rift</i> <i>Comb Grain</i>	1 inch in 12 inches (25.4 mm in 305mm) max. grain slope, 2-1/2 inch in 12 inches (63.5 mm in 305mm) max. grain sweep			
	1/2 inch in 12 inches (12.7 mm in 305mm) max. grain slope, 1/2 inch in 12 inches (12.7 mm in 305mm) max. grain sweep			

Unfilled worm holes, open splits, open joints, open bark pockets, shake or doze not permitted in above grades.

Notes: a. Sap is permitted in rotary only unless otherwise specified.

b. 10% sap is permitted in rift, comb, quartered and plain sliced, 20% sap allowed in rotary

c. Outside components will be a different size to allow for edge trim loss and certain types of matching.

## DOOR FACE DESCRIPTION – Pecan and Hickory

(Adapted from HPVA with permission)

Cut	Plain-Sliced (Flat-Cut) and Quarter Cut	
Grade Description	AA	A
<b>Color and Matching</b>		
Sapwood	Yes	Yes
Heartwood	Yes	Yes
Color Streaks or Spots	Yes	Yes
Color Variation	Yes	Yes
Sharp Color Contrasts at Splice Joints	Yes, if Slip, Plank or Random matched	Yes, if Slip, Plank or Random matched
<b>Type Of Matching</b>		
Book Matched	Yes	Yes
Slip Matched	Specify	Specify
Pleasing Matched	not applicable	not applicable
Nominal Minimum Plain Sliced	5 inches (127 mm)	4 inches (102 mm)
Width of Leaves (c) Quarter/Rift	3 inches (76 mm)	3 inches (76 mm)
Rotary	5 inches (127 mm)	4 inches (102 mm)
<b>Natural Characteristics (except as limited below, natural characteristics are not restricted)</b>		
Small Conspicuous Burls & Pin Knots-Combined Avg. Number	1 per sq. ft. (11 per sq. m)	2 per sq. ft. (22 per sq. m)
Conspicuous Burls - Max. Size	1/4 inch (6.4 mm)	3/8 inch (9.5 mm)
Conspicuous Pin Knots (b)		
Avg. Number	1 per 2 sq. ft. (6 per sq. m)	2 per 1 sq. ft. (22 per sq. m)
Max. Size: Dark Part	1/8 inch (3.2 mm)	1/8 inch (3.2 mm)
Total	1/4 inch (6.4 mm)	1/4 inch (6.4 mm)
Scattered Sound and Repaired Knots - Combined Avg. No.		
Max. Size - Sound	No	No
Max. Size - Repaired		
Avg. No. - Repaired		
Mineral Streaks	Slight	Slight
Bark Pockets	No	Small, Occasional
Worm Tracks	No	Slight
Vine Marks	Slight	Occasional
Cross Bars	Slight	Occasional
<b>Manufacturing Characteristics</b>		
Rough Cut / Ruptured Grain	No	No
Blended Repaired Tapering Hairline Splits	Two 1/32 inch x 3 inch (Two 0.8 mm x 76 mm) (on ends only)	Two 1/16 inch x 6 inch (Two 1.6 mm x 152 mm)
Repairs	Very Small Blending	Small Blending
<b>Special Characteristics (except as limited below, special characteristics are not restricted)</b>		
Bird Peck (c)	No	Slight
Knife Marks	Knife marks may occur in these high density species.	
Quarter Cut	1 inch in 12 inches (24.4 mm in 305 mm) maximum grain slope, 2-1/2 inches in 12 inches (63.4 mm in 305 mm) maximum grain sweep	

Unfilled worm holes, open splits, open joints, open bark pockets, shake or doze not allowed in above grades.

Notes: a. Outside components will be a different size to allow for edge trim loss and certain types of matching.

b. For Pecan and Hickory, conspicuous pin knots means sound knots 1/4 inch (6.4 mm) or less in diameter with dark centers larger than 1/16 inch (1.6 mm). Blending pin knots are sound knots 1/4 inch (6.4 mm) or less in diameter with dark centers 1/16 inch (1.6 mm) or less and are allowed in all grades of Pecan and Hickory.

c. To achieve a more rustic appearance, bird peck shall be specified

## DOOR FACE DESCRIPTION - Walnut and Cherry

(Adapted from HPVA with permission)

Cut	Plain-Sliced (Flat-Cut) and Quarter Cut	
Grade Description	AA	A
<b>Color and Matching</b>		
Sapwood	No	No (a)
Heartwood	Yes	Yes
Color Streaks or Spots	Slight	Slight
Color Variation	Slight	Slight
Sharp Color Contrasts at Splice Joints	Yes, if Slip, Plank or Random matched	Yes, if Slip, Plank or Random matched
<b>Type Of Matching</b>		
Book Matched	Yes	Yes
Slip Matched	Specify	Specify
Pleasant Matched	not applicable	not applicable
Nominal Minimum Plain Sliced	5 inches (127 mm)	4 inches (102 mm)
Width of Leaves (c) Quarter/Rift	3 inches (76 mm)	3 inches (76 mm)
Rotary	5 inches (127 mm)	4 inches (102 mm)
<b>Natural Characteristics (except as limited below, natural characteristics are not restricted)</b>		
Small Conspicuous Burls & Pin Knots-Combined Avg. Number	1 per 4 sq. ft. (3 per sq. m)	1 per 1-1/3 sq. ft. (8 per sq. m)
Conspicuous Burls - Max. Size	1/4 inch (6.4 mm)	3/8 inch (9.5 mm)
Conspicuous Pin Knots (c)		
Avg. Number	1 per 5 sq. ft. (3 per sq. m)	1 per 2 sq. ft. (6 per sq. m)
Max. Size: Dark Part	1/8 inch (3.2 mm)	1/8 inch (3.2 mm)
Total	1/4 inch (6.4 mm)	1/4 inch (6.4 mm)
Scattered Sound and Repaired Knots - Combined Avg. No.		
Max. Size - Sound	No	No
Max. Size - Repaired		
Avg. No. - Repaired		
Mineral Streaks	Slight	Slight
Bark Pockets	No	No
Worm Tracks	No	No
Vine Marks	Slight	Occasional
Cross Bars	Slight	Occasional
<b>Manufacturing Characteristics</b>		
Rough Cut / Ruptured Grain	No	No
Blended Repaired Tapering Hairline Splits	Two 1/32 inch x 3 inch (Two 0.8 mm x 76 mm) (on ends only)	Two 1/16 inch x 6 inch (Two 1.6 mm x 152 mm)
Repairs	Very Small Blending	Small Blending
<b>Special Characteristics (except as limited below, special characteristics are not restricted)</b>		
Gum Spots	Occasional gum spots permitted in Cherry	Occasional gum spots permitted in Cherry
Quarter Cut	1 inch in 12 inches (25.4 mm in 305 mm) maximum grain slope, 2-1/2 inches in 12 inches (63.4 mm in 305 mm) maximum grain sweep.	

Unfilled worm holes, open splits, open joints, open bark pockets, shake or doze not allowed in above grades.

- Notes:
- Sap is allowed in grades A however, the percentage must be agreed upon between buyer and seller.
  - Outside components will be a different size to allow for edge trim loss and certain types of matching.
  - For Walnut and Cherry, conspicuous pin knots mean sound knots 1/4 inch (6.4mm) or less in diameter with dark centers larger than 1/16 inch (1.6mm). Blending pin knots are sound knots 1/4 inch (6.4mm) or less in diameter with dark centers of 1/16 inch (1.6mm) or less and are allowed in all grades of Walnut and Cherry.

## DOOR FACE DESCRIPTION –Western Red Alder

(Adapted from HPVA with permission)

Cut	Plain-Sliced (Flat-Cut)		
Grade Description	A	B	C/ Rustic
<b>Color and Matching</b>			
Sapwood	Yes	Yes	Yes
Heartwood	Yes	Yes	Yes
Color Streaks	Slight	Slight	Yes
Color Variation	Slight	Slight	Yes
Nominal Minimum Width of Leaves	3 inches (76 mm)	3 inches (76 mm)	3 inches (76 mm)
<b>Type of Matching</b>			
Plank Matched for pleasing appearance	Yes	Yes	Yes
Book Matched for color and grain at the joints	Specify	Specify	Specify
<b>Natural Characteristics</b>			
Conspicuous Burls- Max. Size	1/2 inch (12.7 mm)	Yes	Yes
Pin Knots	Yes	Yes	Yes
Bark Pockets	No	Few - Maximum Size 1/4 inch x 2 inches (6.4mm x 50.8mm)	Unlimited in number Maximum size 1/4 inch x 4 inches ((6.4mm x 102mm)
Sound Knots - Max Size (may contain dark centers)	1/2 inch (12.7 mm)	2 inches (50.8 mm)	Yes
Repaired Knot Holes - Number; Maximum Size	Two; 1/4 inch (6.4mm) Max Dia.	Six; 3/4 inch (19 mm) Max. Dia.	Unlimited; 1 1/2 inches (38 mm) Max. Dia.
<b>Manufacturing Characteristics</b>			
Rough Cut	No	Small Areas Allowed	Small Areas Allowed
Stain	No	Slight	Yes
Blended Repaired Tapering Hairline Splits	Two; 1/16 inch x 6 inches (1.6mm x 152 mm) on panel ends	Three; 1/8 inch x 10 inches (3.2 mm x 254 mm) on panel ends	1/8 inch x 12 inches (3.2mm x 305mm)
Repairs	Blending	Blending	Yes
Special Characteristics	-	Open Knots	-

- Notes: a. The general color of individual components shall not be significantly lighter or darker than that of the other components in the face.  
b. Book Matched Grade B – one row of unlimited 3/4 inch (19 mm) open knots is allowed.

## DOOR FACE DESCRIPTION - White Pine

(Adapted from HPVA with permission)

Cut	Plain-Sliced (Flat-Cut) and Quarter Cut		
Grade Description	A (Face)	B (Face)	C (Face) (a)
<b>Color and Matching</b>			
Sapwood	Yes	Yes	Yes
Heartwood	Yes	Yes	Yes
Color Streaks	Slight	Yes	Yes
Color Variation	No	Slight	Yes
Stain, Blue and Brown	No	Slight	Yes
<b>Type of Matching</b>			
Plank Matched for pleasing appearance	-	-	-
Book Matched for color and grain at the joints	Yes	Yes	NA
<b>Natural Characteristics</b>			
Burls	Yes	Yes	Yes
Pin Knots	Yes	Yes	Yes
Sound Knots; Max. Size	2 inches (50.8mm)	3 1/2 inches (89 mm)	Yes
Spike Knots; Max. Size	2 inches (50.8mm)	3 1/2 inches (89 mm)	Yes
Repaired Knot Holes; Max. Size	3/4 inch (19 mm)	1-1/2 inches (38 mm)	Unlimited
Pitch Streaks	Small	Small	Yes
Pitch Pockets	Few to 1/8 inch x 1 inch (3.2mm x 25.4 mm)	Few to 1/8 inch x 2 inches (3.2 mm x 50.8 mm)	Yes
Crows Foot	Slight	Occasional/ Yes	Yes
<b>Manufacturing Characteristics</b>			
Rough Cut	No	Slight	Yes
Blended Repaired Tapering Hairline Splits	Yes	Yes	Yes (b.)
Repairs	Blending	Blending	Yes
Cross Bars	-	Open Knots	

Unfilled wormholes, open splits, open joints, ruptured grain, or doze not allowed in grades A and B above

- Notes: a. All knotty White Pine complying with this Standard shall meet the C (Face) grade requirements unless otherwise specified.  
b. Open hairline checks and splits up to 12 inches (305mm) long and 1/8 inch (3.2mm) wide allowed.



## DOOR FACE DESCRIPTION - Douglas Fir and \*Redwood

(Adapted from HPVA with permission)

\*Very limited availability

Cut	Sliced - Vertical Grain	
Grade Description	A	A
	Douglas Fir	Redwood
<b>Color and Matching</b>		
Sapwood	Limited - No bright Sapwood	Yes
Heartwood	Yes (a.)	Yes (a.)
Color Streaks	No	No
Color Variation	Slight	Slight
Stain, Blue and Brown	No	No
<b>Type of Matching</b>		
Book Matched - matched for color and grain at the joints	Yes	Yes
Slip Matched - for color	Yes	Yes
<b>Natural Characteristics</b>		
Burls	Small	Small
Pin Knots	No	Yes
Sound Knots; Max. Size	No	No
Spike Knots; Max. Size	No	No
Repaired Knot Holes; Max. Size	No	No
Pitch Streaks	Small	No
Pitch Pockets	No	No
Crows Foot	No	No
<b>Manufacturing Characteristics</b>		
Rough Cut	No	No
Blended Repaired Tapering Hairline Splits	Yes	Yes
Repairs	Blending	Blending
Cross Bars	No	No

Note: a. Heartwood must have 6 or more annual rings per inch (6 per 25 mm).

## A-9: Fabrication

### General Requirements

#### Workmanship

Exposed and semi-exposed surfaces are to be free of tear out, chips, dents, gouges, tool marks, adhesive residue, sand through, cross sanding, over/under filling, sharp edges, or similar defects in any 10 square feet (1 square meter) of surface area per grade as follows: (See Section F-6 for visual inspection standards for factory finished doors)

- Custom grade – Maximum of 5 not to exceed 1/32 inch (0,8 mm)
- Premium grade – None

#### Veneer Faces, Opaque or Transparent Finish

- Joints must be tight.
- Veneer faces must be completely glued to substrate.
- Veneer faces shall be thoroughly sanded.
- Bleed through of glue at veneer joints that visually affects an applied finish is not permitted.
- Figure is not a function of species grade and any special desires must be so specified.

#### Vertical Edges, Opaque or Transparent Finish

- Vertical edges shall be smoothly sanded, free of knife and saw marks.
- Voids are not permitted between veneer layers and solid wood edges.
- When allowed under Section C12, the hinge edge may be jointed. Joints must be tight.
- Vertical edges shall have an eased edge at intersections of edges and face veneers.

#### Crossbands

Crossbands, when used, shall be full piece or edge glued without voids.

- For non fire doors exceeding standard size limitations (4 feet (1.2 m) in width and or 10 feet (3.0 m) in height), tight butt joints are allowed.

#### Horizontal Edges

- Joints in horizontal edges shall be without gaps.
- Horizontal edges shall be sound without splits, shake, or doze.
- There shall be no gaps between veneer layers and solid horizontal edges.

# PERFORMANCE

## P-1: Performance Standards for Architectural Wood Flush Doors

Performance is a very important aspect of specifying Architectural Wood Flush Doors and is directly related to the use of the door. The following table identifies the tests that are conducted and the criteria that must be reached in order to qualify a given door assembly for each specific Performance Duty Level

**WDMA I.S.1A Flush Wood Door Minimum Performance Standards**

Performance Attribute	Performance Duty Level		
	Extra Heavy Duty	Heavy Duty	Standard Duty
Adhesive Bond Durability, WDMA TM-6	Type I or Type II	Type I or Type II	Type I or Type II
Cycle Slam, WDMA TM-7	1,000,000 cycles	500,00 cycles	250,000 cycles
Hinge-Loading, WDMA TM-8	550 lbs. (2440 N)	475 lbs. (2110 N)	400 lbs. (1780 N)
Door Finishes Various ASTM test methods	TR-6/OP-6 or equal *	TR-4/OP-4 or equal *	TR-2/OP-2 or equal *
Screwholding, WDMA TM-10			
Door Face (blocked or unblocked)	550 lbs. (2440 N)	475 lbs. (2110 N)	400 lbs. (1780 N)**
Vertical Door Edge	550 lbs. (2440 N)	475 lbs. (2110 N)	400 lbs. (1780 N)
Horizontal Door Edge	300 lbs. (1330 N)	240 lbs. (1060 N)	180 lbs. (810 N)
Telegraph, Section T-1	Maximum 0.010 inch in any 3 inch span (0.25 mm in any 76 mm span)		
Warp Tolerance, Section T-2	Maximum 0.25 inch in any 3'-6" x 7'-0" (6.4 mm in any 1050 mm x 2100 mm) door section		
Squareness, Section T-3	Diagonal variance 1/8 inch (3.2 mm)		

\* See Section F7. Other formulations may exhibit similar performance characteristics, but must meet or exceed the performance levels for the systems specified to be considered as equal.

\*\* If screw holding power is less than 400 lbs. (1780 N) in a Standard Duty door, blocking or thru-bolts are recommended for operable hardware.

## P-2: Example Duty Level Applications

Extra Heavy Duty	Heavy Duty	Standard Duty
Typically involves doors where use is considered heavy and frequent, requiring the highest minimum performance standards.	Typically involves doors where usage is moderate, requiring intermediate minimum performance standards.	Typically involves doors where frequency of use is low, requiring the lowest minimum performance standards.
Classroom	Assisted Living Room Entry	Closet
Patient Rooms	Office - Interior Passage	Wardrobe
Bathroom - Public	Stairwell	Bathroom - Private
Dorm Room	Mechanical Service	Small, low usage Office
Assembly areas	Hallway	
Auditorium Entry	Storage	
Detention/Correctional	Apartment/Condo Entry	
Bullet Resistant	X-Ray	
Gymnasium/Locker Room	Acoustic	
Surgical Entry	Medical Examination Room	
Trauma Centers		
Hotel/Motel Room Entry		

## P-3: Dimensional Information

The following dimensional information and tolerances are determined at the time of shipment. Exposure of the door to variations in temperature and moisture during shipment, storage, and prior to building occupancy may affect the size of door components and their interface.

### Doors

Width:	±1/16 inch (±1.6 mm) not prefit ±1/32 inch (±0.8 mm) factory prefit
Height:	±1/16 inch (±1.6 mm)
Thickness:	±1/16 inch (±1.6 mm)

### Hardware Machining

#### Hinge Mortises

Location:	±1/32 inch (±0.8 mm)
Height:	+1/32 inch, -0 inch (+0.8 mm, -0 mm)
Depth:	+.025 inch, -0 inch (+0.6 mm, -0 mm)
Backset:	+0 inch, -1/32 inch (+0 mm, -0.8 mm)

#### Lock Fronts

Location:	±1/32 inch (±0.8 mm)
Height:	+1/32 inch, -0 inch (+0.8 mm, -0 mm)
Width:	+1/32 inch, -0 inch (+0.8 mm, -0 mm)
Depth:	+.025 inch, -0 inch (+0.6 mm, -0 mm)

### Typical Prefit Clearances

#### Non-fire rated Doors

Top & Hinge Edges	1/8 inch (3 mm) clearance
Lock Edge, Single Door	1/8 inch (3 mm) clearance
Meeting Edges, Pairs	1/16 inch (1.6 mm) per leaf
Bottom Edge	3/4 inch (20 mm) maximum from floor 3/8 inch (10 mm) maximum from top of raised sill

#### Non-fire rated Transoms, Side Lites & Dutch Doors

Width	Per manufacturer's specifications
Height	Per manufacturer's specifications

#### Fire Rated Openings

See NFPA 80 Standard for Fire Doors and Other Opening Protectives

## P-4: Flame Spread Smoke Development

Doors covered by this standard are exempt from Flame Spread Smoke Development requirements in the Model Building Codes.

# TESTS

## T-1: Show Through or Telegraph

Telegraphing of vertical and horizontal edges and cores is considered a defect when the face of the door varies from a true plane in excess of 0.010 inch in any 3 inch span (0.25 mm in any 76 mm span), using a straight edge and feeler gauge or other accurate measuring methods.

The selection of high gloss laminates or finishes should be avoided, because they tend to accentuate natural telegraphing.

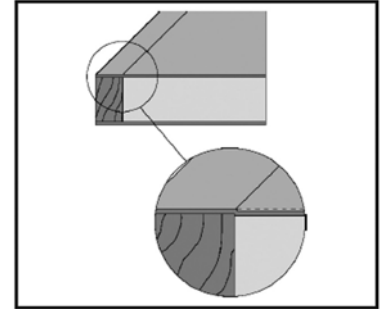

## T-2: Flatness or Warp

Warp is a variation from a plane surface within the door itself. It does not refer to the door in relation to the frame or jamb in which it was hung. Bow, cup, and twist are terms which describe warp in a door and are defined as follows:

**Bow** is a curvature along the door height, or a deviation from a flat plane from end to end.

**Cup** is a curvature across the door width, or a deviation from a flat plane from side to side.

**Twist** is a distortion in which one corner is out of the plane of the other three corners.

Warp is usually a result of unequal stresses within the door from one face to the other caused by changes in humidity and temperature conditions or uneven conditions from one face to the other. Buildings should be humidity and temperature controlled before doors are delivered and installed. Required conditions are 25% to 55% relative humidity and 50° to 90° F (10° to 32° C) temperature range. Improper handling, stacking, and storage can also contribute to warp. Doors should be stored flat on a level surface off the floor with cross supports.

<b>HOW TO MEASURE WARP</b>	
Use a taut string or straight-edge and measure on the concave face of door – diagonally, horizontally, or vertically. Measure at the point of maximum distance between the taut string or straight-edge and the face of the door.	
	<p>Measurement must be made on the concave face of the door.</p> <p>Door should be open when measuring for warp (lock not latched into strike).</p> <p>One person can measure warp using a string and taping one or both ends onto the face of the door, holding it taut.</p> <p>Don't measure warp in relationship to the door frame.</p> <p>Often a door may not fit into the frame properly but is not warped. In these cases, check the frame – it should be set plumb and square, and jambs should not be twisted or out of alignment.</p> <p>Action on any claim for warp may be deferred for up to one year after project completion to permit doors to acclimate to temperature and humidity conditions.</p>
	<p><b>ALLOWABLE WARP TOLERANCE FOR WOOD DOORS</b></p> <p>1-3/4 inch (44 mm) or thicker doors:            3'-6" x 7'-0" (1050 mm x 2100 mm) or smaller, 1/4 inch (6.4 mm) maximum.            Larger than 3'-6" x 7'-0" (1050 mm x 2100 mm), 1/4 inch (6.4 mm) maximum in any 3'-6" x 7'-0" (1050 mm x 2100 mm) section.</p> <p>1-3/8 inch (35 mm) doors:            3'-0" x 7'-0" (900 mm x 2100 mm) or smaller, 1/4 inch (6.4 mm) maximum.            Larger sizes not addressed by this standard.</p>

## T-3: Squareness

All four corners of a door shall be square (right angles). Also, the length of the diagonal measurement on the face of the door from the upper right corner to the lower left corner shall be within 1/8 inch (3.2 mm) of the length of the diagonal from the upper left corner to the lower right corner.

## T-4: Sanding

Sanding is checked for compliance by sanding a sample piece of the same species with the required grit of abrasive.

- A product is sanded sufficiently smooth when knife cuts are removed and any remaining sanding marks are or will be concealed by applied finishing coats.
- Handling marks and/or grain raising due to moisture or humidity in excess of the ranges set forth in this standard shall not be considered as a defect.

## T-5: Joint Gaps

Maximum gaps between exposed components shall be tested with a feeler gauge at points designed to join where members contact or touch. Joints length shall be measured with a ruler with minimum 1/16 inch (1 mm) divisions and calculations made accordingly.

# CONSTRUCTION

## General

Solid Core Doors are customarily manufactured 1-3/4 inches (44 mm) thick; however, other thicknesses are available, such as 1-3/8 inches (35 mm), 2 inches (50 mm) and 2-1/4 inches (57 mm).

Hollow Core Doors are customarily manufactured 1-3/8 inches (35 mm) and 1-3/4 inches (44 mm) thick; however, other thicknesses are available.

## C-1: Face Requirements

### Veneers for Transparent Finishes:

Specie and grade must be specified. In the absence of grade specifications, Custom grade will be furnished. All face veneers for transparent finish to meet requirements of Sections A-3 through A-8.

### Face Materials for Opaque Finishes:

For both Premium and Custom grade, medium density overlay (MDO), medium density fiberboard (MDF), or hardboard faces can be used for applications with opaque finishes. In addition, closed-grain hardwood veneer or other composite material is permitted in Custom grade. When using hardwood veneer, extra preparation is required prior to job site finishing because of the natural characteristics of wood.

### Door Skin Construction:

When wood veneer is used for all plies in door skins of Premium and Custom grade doors, the veneer must be adhered to material with alternating (perpendicular) grain direction and provide for balanced construction. Door skins may also be constructed using composite crossbands.

### Materials for Laminate Faces:

**High Pressure Decorative Laminates (HPDL)** must meet minimum requirements of National Electrical Manufacturers Association (NEMA) Standard LD 3, High-Pressure Decorative Laminates.

**Low Pressure Decorative Laminates (LPDL)** must meet the minimum requirements of the LMA (Laminating Materials Association, Inc.) Voluntary Product Standards and Typical Physical Properties of Decorative Overlays.

## C-2: Crossbanding Requirements

Crossbanding may be wood veneer, or engineered wood products (composites).

## C-3: Core Requirements

### Particleboard Core (PC):

Wood fiber and/or agri-fiber based materials that comply with standard ANSI A208.1, minimum grade LD-1. LD-2 or other core can be used, providing the final door construction meets or exceeds the performance duty levels specified in Section P-1.

### Medium Density Fiberboard Core (MDFC):

Wood fiber and/or agri-fiber based materials that comply with ANSI A208.2.

**Structural Composite Lumber Core (SCLC):** An engineered wood product that is made by fusing a network of wood strands together with a water-resistant adhesive to produce a strong, solid and stable product that has true structural properties with excellent screw holding properties and very high split resistance.

### Staved Lumber Core (SLC):

Made with any combination of blocks or strips, not more than 2-1/2 inches (64 mm) wide, of one specie of wood glued together (in butcher block fashion) with joints staggered in adjacent rows.

### Laminated Veneer Lumber Core (LVLC):

Manufactured by laminating veneer with all grain laid-up parallel. It can be manufactured by using various species of wood fiber in various thicknesses.

### **Fire Resistant Composite Core (FD):**

Fire resistant composite core for fire doors per manufacturer's label service listing.

### **Hollow Core (HC):**

Often made of expanded honeycomb made of corrugated fiberboard. Consult individual manufacturers for additional options. The material and arrangement of interior core support items are intended to prevent telegraphing in compliance with Section T-1.

### **Special Core Types:**

Special core constructions are applicable for Sound Resistant (STC), Lead Lined (X-ray), Bullet Resistant and Electrostatic Shield doors. Consult individual manufacturers for details.

## **C-4: Edge Requirements**

### **Solid Core Doors**

**Vertical Edges (Stiles):** Wood or composite material, one piece, laminated, or veneered. Specific configuration per manufacturer's standard. Minimum requirements are established in Section C-11 and Section A-9. Finger joints are not permitted in Premium grade. One finger joint is permitted in Custom grade at either vertical edge that is tight, not raised, uniform in color and grain, without discoloration, and is not visible at a distance of 6 feet (1.8 m). Veneer backing other than hardwood must be of a material that has been qualified in accordance with WDMA TM-15 Vertical Edge Impact Test Method.

**Horizontal Edges (Rails):** Wood or composite material meeting the minimum requirements of Section C-11 and Section A-9. End rail matching to stiles must be specified if required. Veneer backing other than hardwood must be of a material that has been qualified in accordance with WDMA TM-15 Vertical Edge Impact Test Method.

### **Hollow Core Doors**

**Vertical Edges (Stiles):** Wood or composite material, one piece, laminated, or veneered. Specific configuration per manufacturer's standard. Minimum requirements are established in Section C-11 and Section A-9. Finger joints are not permitted in Premium grade. One finger joint is permitted in Custom grade at either vertical edge that is tight, not raised, uniform in color and grain, without discoloration, and is not visible at a distance of 6 feet (1.8 m).

**Horizontal Edges (Rails):** Wood or composite material, meeting the minimum requirements of Section C-11 and Section A-9. End rail matching to stiles must be specified if required.

## **C-5: Vertical and Horizontal Edge/Core Interface**

There are two types of interface between the core and the edges in solid core doors:

**Bonded:** Vertical and horizontal edges of solid core doors must be securely bonded to the core with adhesives.

**Non-Bonded:** Vertical and horizontal edges are not bonded to the core material. The maximum gap between core and vertical and/or horizontal edges is to be 1/32 inch (0.8 mm). Core and adjacent edging component thickness tolerance is +/- 0.005 inch (0.13 mm) to achieve minimal telegraphing per Section T-1.

## **C-6: Adhesives**

Glue lines for face veneer assembly, between the various plies of the face, between the facing and core assembly, and between edging and core in bonded core assemblies must be either Type I or Type II that meet the requirements specified in WDMA TM-6 Adhesive Bond Durability Test Method.



## C-7: Construction Details

### Meeting Edge Specify by number

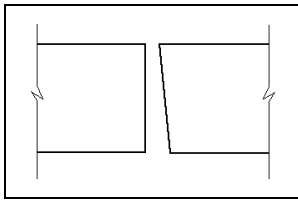

E1: One Bevel  
(bevel active leaf)

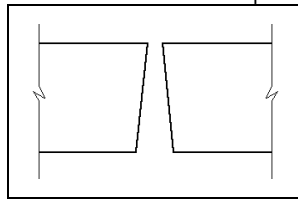

E2: Two Bevel

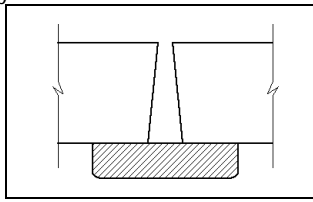

E3 Flat Astragal  
(one or two bevel)

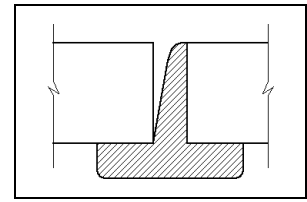

E4: Tee Astragal  
(one or two bevel)

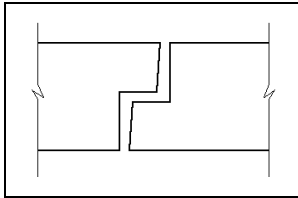

E5: Rabbeted  
(bevel or square)

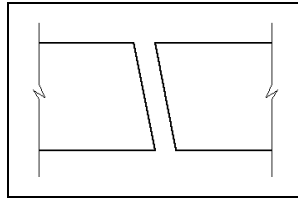

E6: Parallel Bevel  
(double egress)

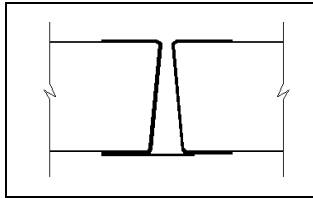

E7: Metal Edge Guard (bevel)  
& Astragal  
(bevel or square)

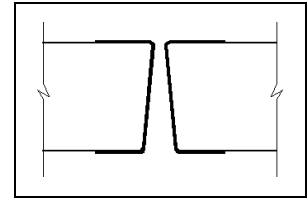

E8: Metal Edge Guard  
(inactive edge  
may be square)

### Dutch Door Specify by number

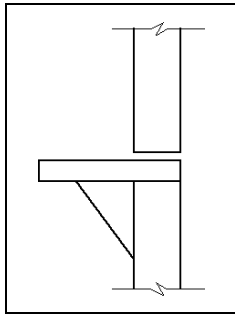

D1: One-Side Shelf

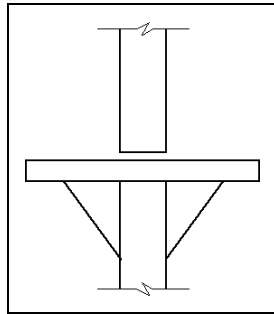

D2: Two-Side Shelf

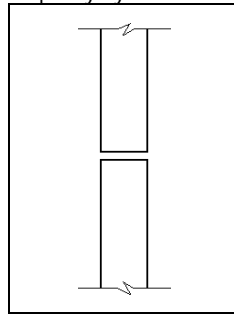

D3: Non Rabbeted

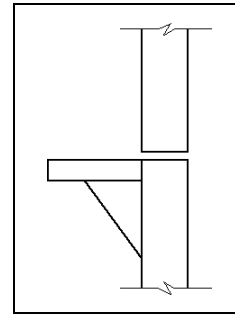

D4: Non-Rabbeted  
with side shelf

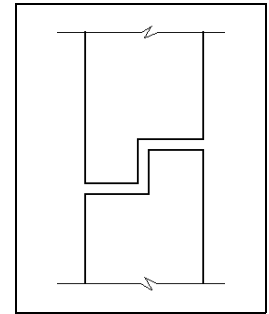

D5: Rabbeted

### Transom Meeting Edge Specify by number

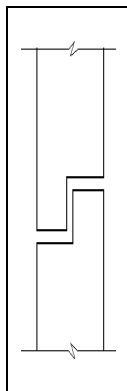

T1:  
Rabbeted

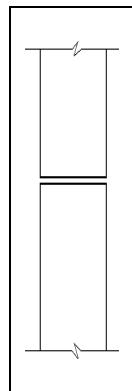

T2: Non-  
Rabbeted

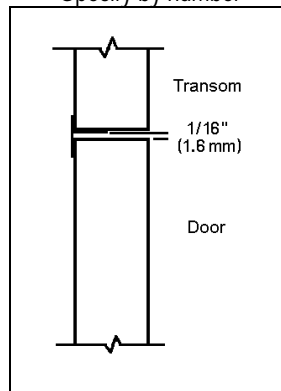

T3: Astragal

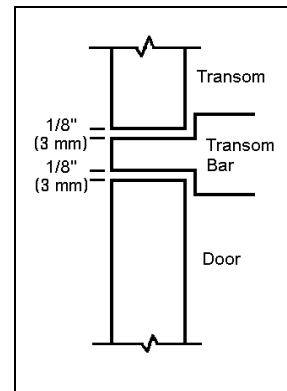

T4: Transom Bar

Illustrations on this page, except for Option E1, Option T3 and Option T4, reprinted with permission from the Architectural Woodwork Institute, Reston, Virginia

## Glazing

Specify by number



W = Wood Moulding  
M = Metal Moulding  
Number indicates size. For example, 2830 is 28 inches wide x 30 inches high (711 mm x 762 mm)

Generally, cutouts in fire rated doors for metal or wood vision panels are a minimum of 5-1/2 inches (140 mm) from the vertical edge of the door or other cutouts; for non-fire rated doors, the distance is most commonly 5 inches (127 mm). Dimensions may vary depending on construction or manufacturer's warranty. Using a 10 inch margin between the edge of the door and the edge of any vision lite cutout near the lock area will eliminate most label and warranty conflicts.

## Louver

Specify by number\*

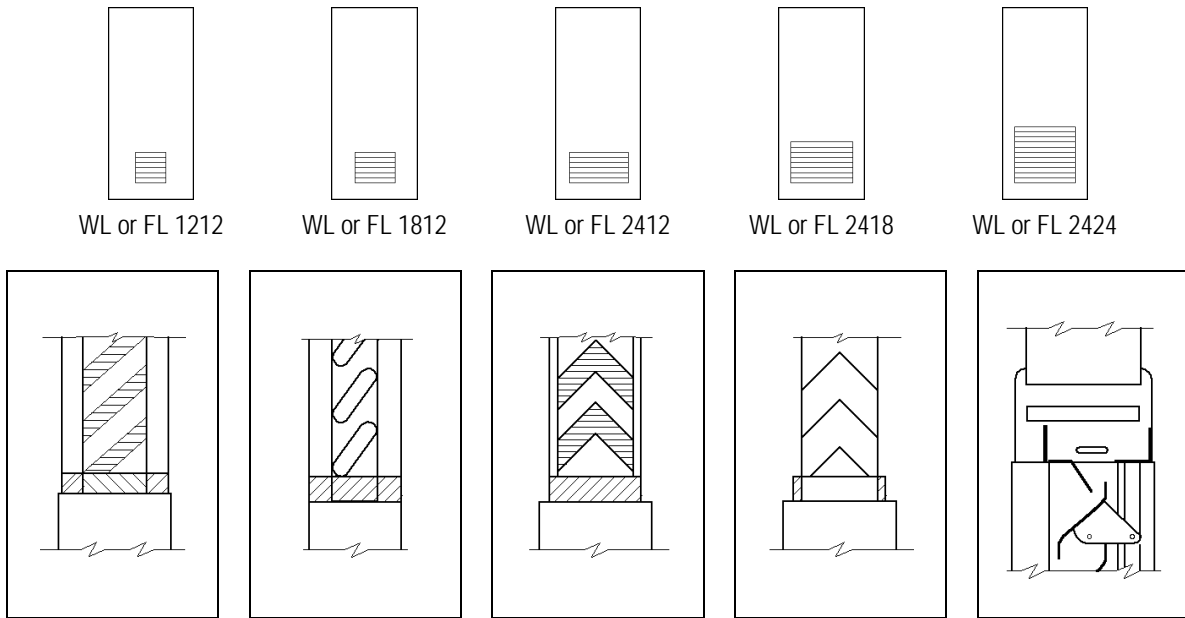

L1: Slats, wood  
L2: Slats, wood  
L3: Chevrons, wood  
L4: Chevrons, metal  
L5: Fusible Link

WL = Wood Louver  
FL = Fusible Link Louver  
Number indicates size. For example, 2412 is 24 in. (X mm) wide x 12 in. (Y mm) high.

Louvers are not allowed in means-of-egress fire doors per NFPA 80. Generally, fusible link louvers installed in 45, 60, and 90 minute fire rated doors must comply with individual fire door authorities and ADA requirements. Dimensions may vary depending on construction or manufacturer's warranty

Illustrations on this page, except for Option M3, reprinted with permission from the Architectural Woodwork Institute, Reston, Virginia

### Wood Bead Options

Specify by number

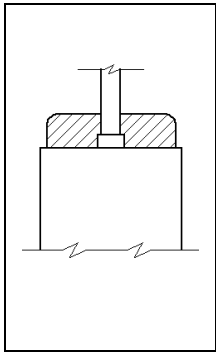

M1: Recessed Bead

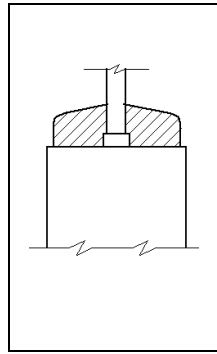

M2: Recessed Bead

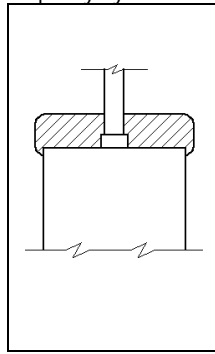

M3: Lip Bead

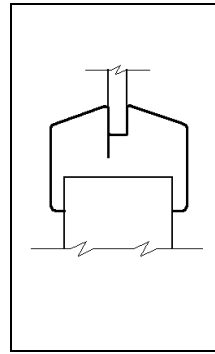

M4: Metal Vision Frame

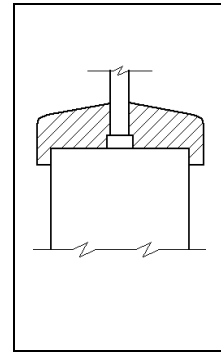

M5: Lip Bead

See Section C-11 for matching requirements.

Specify transparent or opaque finish.

Bead shall be free of open defects, shake, splits, or doze.

Bead must be smooth and free of visible knife, saw, or sanding marks when viewed at a distance of 3 ft. (0.9 m) for premium grade and 6 ft. (1.8 m) for custom grade.

Some variances may occur in the fit of flush-type bead due to door thickness, moulding width and glazing material thickness. The glazier is responsible for the aesthetic appearance of the lite opening

### Blocking (Reinforcement) Options

Specify by letter, location and dimension.



HB1



HB2



HB3

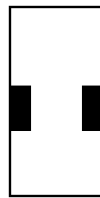

HB4

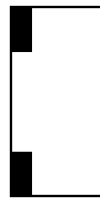

HB5



HB6



HB7

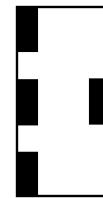

HB8

## C-8: Fire Doors

### Fire Door Ratings and Openings Classification

The Model Codes have established a fire door rating system for door assemblies that protect openings in fire resistant rated wall constructions. In 1997, the International Council of Building Officials (ICBO) approved a change to the Uniform Building Code (UBC) that requires fire doors to be tested under positive pressure instead of neutral pressure. Many states and local jurisdictions across the U.S. have adopted the International Building Code (IBC) which also contains the requirement for positive pressure.

It is very important that architects, contractors and distributors are aware of the requirements in their area so the appropriate type of door is supplied (neutral or positive pressure). Door manufacturers are not responsible for interpretations of local codes.

All fire doors must meet the requirements of recognized fire door tests and bear certifying labels of an independent testing agency approved by the building official.

Installation is required to be in accordance with the National Fire Protection Association's Publication NFPA 80, Standard for Fire Doors and Other Opening Protectives. Machined fire doors shall be provided with detailed installation instructions when doors bear a label indicating compliance to UBC 7-2-or UL 10C.

Requirements for fire ratings and neutral or positive pressure depend upon local codes; door manufacturers are not responsible for interpretations of local code requirements.

### Important Facts to Consider When Reading Specifications

Key phrases indicating positive pressure	Key phrases indicating negative (neutral) pressure	Phrases that don't indicate either positive or negative pressure
<ul style="list-style-type: none"> <li>• UBC 7-2-1997 – UBC Fire Test</li> <li>• International Building Code (IBC)</li> <li>• NFPA 5000 – Building Construction and Safety Code</li> <li>• UL 10C – Fire Test</li> <li>• After 5 minutes into the test the neutral pressure plane should be at 40 inches</li> <li>• Shall meet positive pressure requirements</li> <li>• Intumescent seals – not telling you it is positive pressure but implying that it is.</li> </ul>	<ul style="list-style-type: none"> <li>• UL 10B – Fire Test</li> <li>• UBC 7-2-1994 – UBC Fire Test</li> <li>• UBC 43-2 – UBC Fire Test</li> <li>• Tested at atmospheric pressure</li> <li>• Neutral pressure</li> <li>• Negative pressure</li> <li>•</li> </ul>	<ul style="list-style-type: none"> <li>• NFPA 101 – Life Safety Code</li> <li>• NFPA 105 – Standard for the Installation of Smoke Door Assemblies and Other Opening Protectives</li> <li>• NFPA 252 – Fire Test method which gives the option to be positive or negative</li> <li>• UBC – With no date given could be either positive or negative</li> <li>• UL 1784 – Air Leakage Test for Door Assemblies</li> <li>• NFPA 80 – Installation standard for fire doors</li> </ul>

There are two categories of doors available for positive pressure fire openings.

**Category A** doors have the door-to-frame sealing system incorporated (concealed or visible) into the door edge at the licensed manufacturer or machining distributor. Refer to the manufacturer's listing or installation instructions for meeting edges, which may require an astragal or field-applied edge sealing system.

**Category B** doors require a field-applied edge-sealing system between the labeled frame and door. The application of the edge-sealing system cannot require any field machining of the frame or door. Refer to the manufacturer's listings or installation instructions for meeting edge requirements, which may not require a field applied edge sealing system. Refer to the individual door listing and Category G, Edge-Sealing Systems for individual manufacturer's requirements.

### Smoke and Draft Control Rating [S] (Category H)

Many positive pressure openings will also require a smoke seal. An "S" label requirement indicates the opening needs to have Smoke and Draft Control Gasketing. Category H includes gasket systems that are surface-applied to the perimeter of the door or frame. They may be kerf applied, adhesive backed or mechanically attached. It includes gasketing for the meeting edges. This category covers gasket systems that have been evaluated for use in positive pressure rated assemblies but generally do not provide an edge-sealing system to the opening as described below.

### Edge-Sealing Systems (Category G)

Category G includes field applied systems only. Category G Edge-Sealing Systems are for use on Category B doors, or meeting edges (only) of Category A doors. These systems are surface-applied to either the perimeter of the door or frame, or meeting edge of the door. They may be kerf-applied, adhesive-backed, or mechanically fastened.

## Door Specification Descriptors

Section D-1 lists the different types of flush door constructions available in the industry. Fire rated flush doors for positive pressure openings are designated with the "PP" suffix. Stile and Rail doors as described by WDMA I.S. 6A are also available for positive pressure openings based on specific manufacturer's approvals.

### Labeling and Listing

The U.S. model building codes require fire doors to be labeled. The label indicates the rating and is a permanent identifying mark attached to the door. A certification organization provides random unannounced inspection of the production of fire doors. Labeling on the door indicates compliance with the requirements of the certification organization. In addition to the door, the door frame, glazing and hardware are required to be labeled for use with a specific fire door. NFPA 80 requires that all fire doors must be self-closing and self-latching.

## C-9: Special Function Doors

### Sound Resistant (STC)

Sound Resistant Doors are specified by the Sound Transmission Class (STC) ratings as determined by ASTM E-90 and ASTM E413. These doors are certified by the manufacturer with regard to their sound resistance. There are a variety of ways in which sound resistance is achieved. The assigned STC rating shall reflect the operable value. To ensure acceptable sound resistance of the door, specifications should indicate the operable STC rating that is required. Door thickness may exceed 1-3/4 inches (44mm). Consult manufacturer for details of gasketing, automatic door seals, thresholds, frames or hardware which may be required.

### Lead Lined (X-ray)

Lead Lined doors are usually manufactured with a Particleboard, Structural Composite Lumber, or Staved Lumber Core and have continuous lead sheet(s) from edge to edge in the center of the door or between the crossbanding and the core. The total thickness of the lead sheet(s) determines the shield rating. Various thicknesses of lead sheets are available.

Thickness	Corresponding Weight
1/32 inch (0.8 mm)	2 lb. (0.9 kg)
1/16 inch (1.6 mm)	4 lb. (1.8 kg)
1/8 inch (3.2 mm)	8 lb. (3.6 kg)
3/16 inch (4.8 mm)	12 lb. (5.4 kg)
1/4 inch (6.4 mm)	16 lb. (7.3 kg)

### Bullet Resistant

Bullet resistant doors are manufactured with special ballistic rated materials within the core assembly. They are available to meet or exceed protection levels defined in UL 752 or NIJ. 0108.01 performance standards. When specifying bullet resistant doors, identify what protection level is required.

### Electrostatic Shield

These doors are manufactured with wire mesh or lead either in the center of the core or between the crossbanding and the core. The mesh or lead is grounded with electrical leads through the hinges to the frame. For electrostatic shield doors manufactured with wire mesh, specify the number and location of electrical leads.

## C-10: Environmental Doors

### What is "Green"?

The word "Green" is so often used in the context of environmental responsibility and sustainability yet is hard to quantify definitively. Green to an environmentalist may be drastically different than green to a manufacturer. The challenge is finding common ground that promotes and rewards environmental responsibility as well as product design and performance that is balanced with the rigors and challenges of manufacturing products that need to be competitive in the marketplace.

Many manufacturers are capable of producing doors that can qualify for environmental credits. These include specific credits in the LEED, Green Globes, FSC, SFI, SCS and other programs applicable to doors. Check with the door manufacturer to determine how their door products can contribute.

## C-11: Face, Edge, Moulding and Transom Matching Standards

### WDMA I.S.1A Minimum Aesthetic Standards for Wood Veneer Faced Doors

DOOR FEATURES	Premium Grade		Custom Grade	
	Transparent Finish	Opaque Finish	Transparent Finish	Opaque Finish
Veneer Face	AA grade Veneer Edge glued joints	MDO, MDF, or hardboard	A grade Veneer* Edge glued joints	Closed-grain hardwood veneer, MDO, MDF, hardboard, or other composite materials
Veneer Match	Book (default), Slip or Random Match	N/A	Book (default), Slip or Random Match	N/A
Veneer Face Assembly (default)	Center Balance. Outer leaves not less than 1/2 inch narrower than other leaves	N/A	Running	N/A
Optional Face Assembly	Other face assembly options are available, but must be specified	N/A	Other face assembly options are available, but must be specified. If Center Balance, outer leaves not less than 1 inch narrower than other leaves,	N/A
Vertical Edges (Visible Surface)	Same Specie as Veneer Face** Solid or Veneered No Joints	Closed Grain Hardwood, Veneer, or MDO No Joints	Compatible Specie to Veneer Face One finger joint allowed if not visible from a distance of 6 feet	Closed Grain Hardwood, Veneer, or MDO One finger joint allowed if not visible from a distance of 6 feet
Sanding	See Section T-4			
Joint Gaps, T5	Shall not exceed 0.012 inch (0.3 mm) in width at flat surfaces, nor more than 0.025 inch (0.65 mm) at shaped surfaces.		Shall not exceed 0.025 inch (0.65 mm) in width at flat surfaces, nor more than 0.050 inch (1.3 mm) at shaped surfaces.	
Wood Mouldings Lites, Louvers, etc.	Same Specie as Veneer Face** Solid or Veneered No Joints	Closed Grain Hardwood. Solid or Veneered	Compatible Specie to Veneer Face Solid or Veneered	Closed Grain Hardwood Solid or Veneered
Pair/Set Match	Well matched for color and grain	N/A	Compatible for color and grain	N/A
Door/Transoms	Continuous Match***	N/A	Continuous or End Match	N/A
Transom Meeting Edges (Full width of door/transom)	Same Specie as Door Face Solid or Veneered	Closed Grain Hardwood Solid or Veneered	Compatible Specie to Door Face Solid or Veneered	Closed Grain Hardwood Solid or Veneered

\* AA Grade balanced match may be specified when adjacent to AA grade millwork or as otherwise required.

\*\* Birch faced doors may use compatible species edges, lites, and moulding due to scarcity of birch lumber.

\*\*\* If not restricted by veneer length availability.

### WDMA I.S.1A Minimum Aesthetic Standards for Laminate Faced Doors

DOOR FEATURES	Premium Grade		Custom Grade	
	Woodgrains	Solid Colors or Patterns	Woodgrains	Solid Colors or Patterns
High Pressure Decorative Laminate Face	Meets or exceeds NEMA LD-3	Meets or exceeds NEMA LD-3	Meets or exceeds NEMA LD-3	Meets or exceeds NEMA LD-3
Low Pressure Decorative Laminate Face	Meets or exceeds LMA rqmts. for Saturated Papers	Meets or exceeds LMA rqmts. for Saturated Papers	Meets or exceeds LMA rqmts. for Saturated Papers	Meets or exceeds LMA rqmts. for Saturated Papers
Pairs and Sets	Matching not available	N/A	Matching not available	N/A
Vertical edges (visible surface)	Matching HPDL or PVC	Matching HPDL or PVC	Matching HPDL or PVC	Matching HPDL or PVC
Wood Mouldings (lites, louvers, etc.)	Compatible Species Solid Lumber or Veneered Transparent (stain) Finish (a)	Closed Grain Hardwood Solid Lumber or Veneered Paint Finish (b)	Compatible Species Solid Lumber or Veneered Transparent (stain) Finish (a)	Closed Grain Hardwood Solid Lumber or Veneered Paint Finish (b)
Doors/Transoms	Door and Transom Grain Continuous Match (c)	N/A	Door and Transom Grain Continuous Match (c)	N/A
Transom Meeting Edges (full width of door/transom)	Matching HPDL or PVC	Matching HPDL or PVC	Matching HPDL or PVC	Matching HPDL or PVC
<b>Options for transom bottom edge. Must be specified if desired.</b>				
Optional bottom edge: for transoms option T1 & T2 (full width of door/transom)	Compatible Species with Transparent (stain) Finish (a)	Close Grain Hardwood with Paint Finish (b)	Compatible Species with Transparent (stain) Finish (a)	Close Grain Hardwood with Paint Finish (b)

Note: a. Species and transparent (stain) finish for edges and wood mouldings to be approved by architect.

b. Paint finish to match laminate color or harmonize with patterns.

c. Up to a total assembly height of 144 inches.

## C-12: Door Construction Details

### Wood Veneer Particleboard Core

PC-5 Bonded  
FPC-5 Non-Bonded

PC-7 Bonded  
FPC-7 Non-Bonded

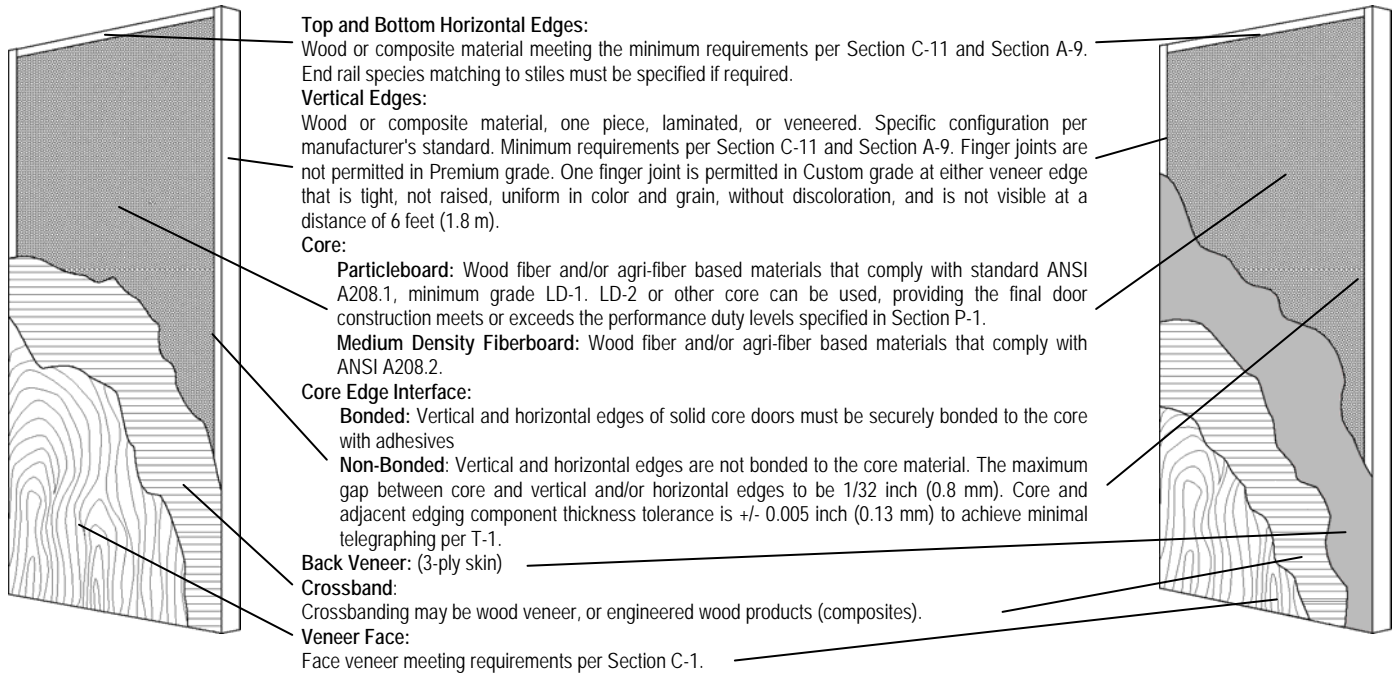

## Wood Veneer Fire Resistant Composite Core

FD-45-5, 60-5, 90-5  
FD-45PP-5, 60PP-5, 90PP-5

FD-45-7, 60-7, 90-7  
FD-45PP-7, 60PP-7, 90PP-7

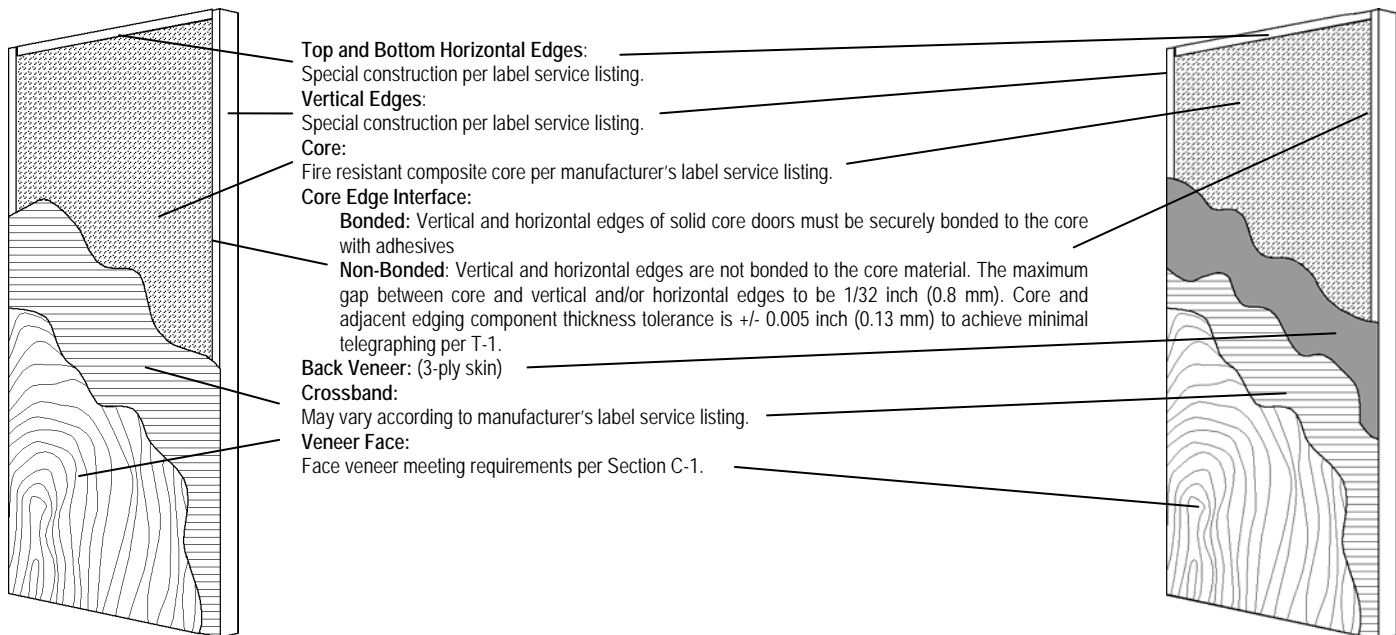

Illustrations on this page reprinted with permission from the Architectural Woodwork Institute, Reston, Virginia

## HPDL Particleboard Core

PC-HPDL-3 Bonded  
FPC-HPDL-3 Non-Bonded

PC-HPDL-5 Bonded  
FPC-HPDL-5 Non-Bonded

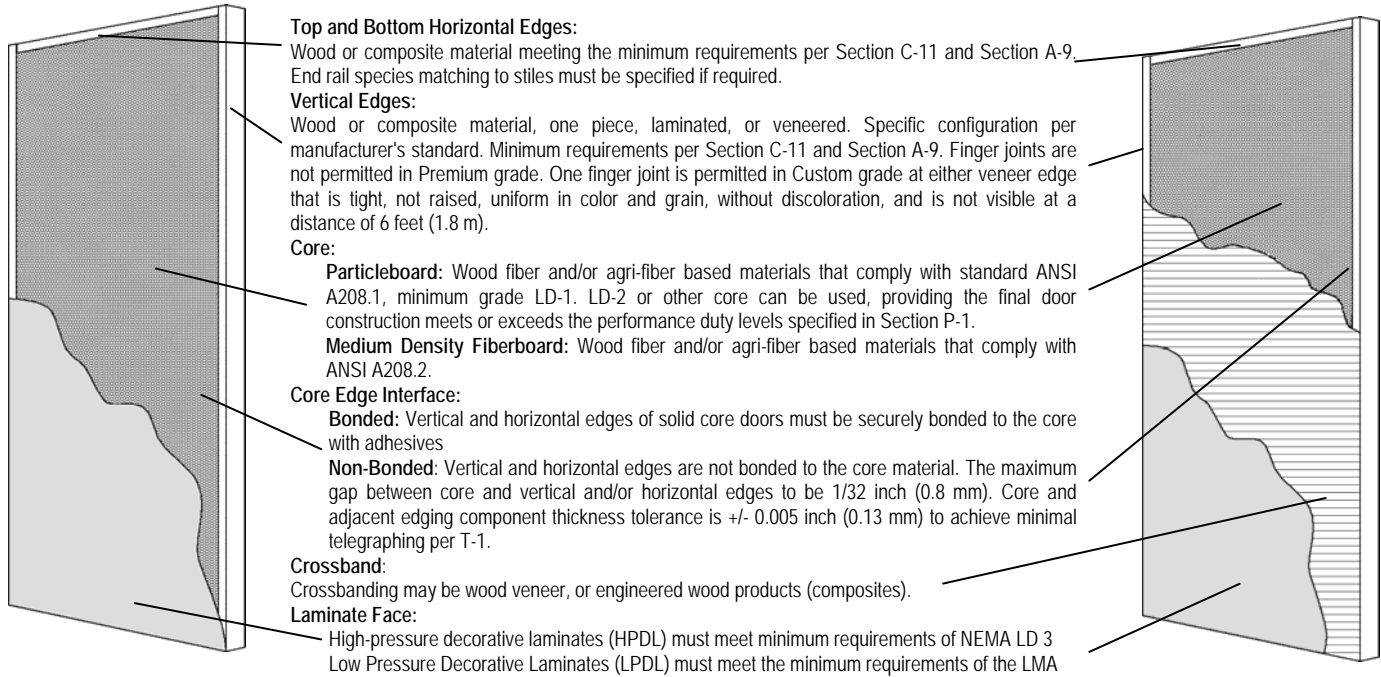

## HPDL Fire Resistant Composite Core

FD-45-HPDL-3, 60-3, 90-3  
FD-45PP-HPDL-3, 60PP-3, 90PP-3

FD-45-HPDL-5, 60-5, 90-5  
FD-45PP-HPDL-5, 60PP-5, 90PP-5

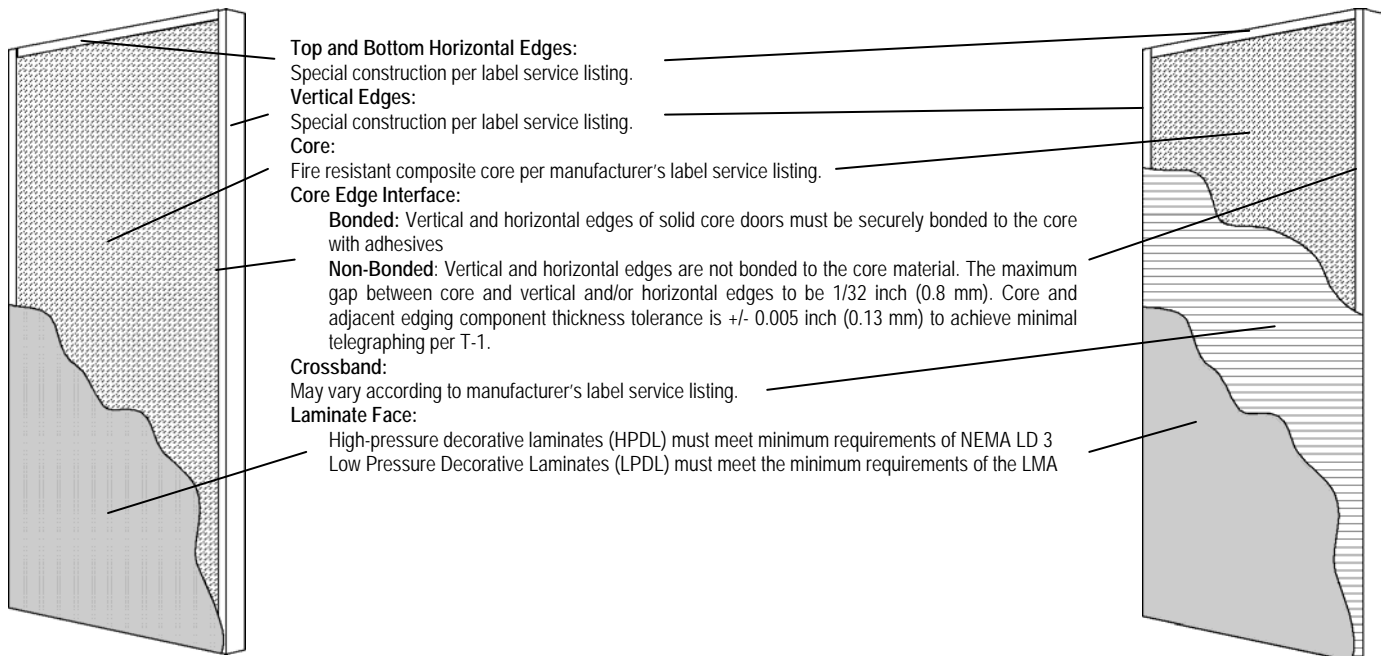

Illustrations on this page reprinted with permission from the Architectural Woodwork Institute, Reston, Virginia



### Wood Veneer Structural Composite Lumber Core

SCLC-5 Bonded  
 FSCLC-5 Non-Bonded

SCLC-7 Bonded  
 FSCLC-7 Non-Bonded



**Vertical Edges:**

Wood or composite material, one piece, laminated, or veneered. Specific configuration per manufacturer's standard. Minimum requirements per Section C-11 and Section A-9. Finger joints are not permitted in Premium grade. One finger joint is permitted in Custom grade at either veneer edge that is tight, not raised, uniform in color and grain, without discoloration, and is not visible at a distance of 6 feet (1.8 m).

**Core:**

An engineered wood product that is made by fusing a network of wood strands together with a water-resistant adhesive to produce a strong, solid and stable product that has true structural properties with excellent screw holding properties and very high split resistance.

**Core Edge Interface:**

**Bonded:** Vertical edges of solid core doors must be securely bonded to the core with adhesives  
**Non-Bonded:** Vertical edges are not bonded to the core material. The maximum gap between core and vertical edges to be 1/32 inch (0.8 mm). Core and adjacent edging component thickness tolerance is +/- 0.005 inch (0.13 mm) to achieve minimal telegraphing per T-1.

**Back Veneer:** (3-ply skin)

**Crossband:**

Crossbanding may be wood veneer, or engineered wood products (composites).

**Veneer Face:**

Face veneer meeting requirements per Section C-1.



### Wood Veneer Staved Lumber Core

SLC-5 Bonded  
 FSCLC-5 Non-Bonded

SLC-7 Bonded  
 FSCLC-7 Non-Bonded

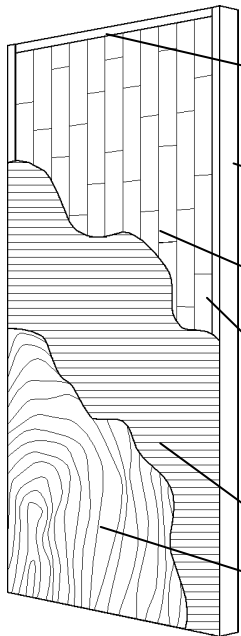

**Top and Bottom Horizontal Edges:**

Wood or composite material meeting the minimum requirements per Section C-11 and Section A-9, End rail matching to stiles must be specified if required.

**Vertical Edges:**

Wood or composite material, one piece, laminated, or veneered. Specific configuration per manufacturer's standard. Minimum requirements per Section C-11 and Section A-9. Finger joints are not permitted in Premium grade. One finger joint is permitted in Custom grade at either veneer edge that is tight, not raised, uniform in color and grain, without discoloration, and is not visible at a distance of 6 feet (1.8 m).

**Core:**

Made with any combination of blocks or strips, not more than 2-1/2 inches (64 mm) wide, of one species of wood glued together (in butcher block fashion\_) with joints staggered in adjacent rows.

**Core Edge Interface:**

**Bonded:** Vertical and horizontal edges of solid core doors must be securely bonded to the core with adhesives

**Non-Bonded:** Vertical and horizontal edges are not bonded to the core material. The maximum gap between core and vertical and/or horizontal edges to be 1/32 inch (0.8 mm). Core and adjacent edging component thickness tolerance is +/- 0.005 inch (0.13 mm) to achieve minimal telegraphing per T-1.

**Back Veneer:** (3-ply skin)

**Crossband:**

Crossbanding may be wood veneer, or engineered wood products (composites).

**Veneer Face:**

Face veneer meeting requirements per Section C-1.



Illustrations on this page reprinted with permission from the Architectural Woodwork Institute, Reston, Virginia

## HPDL Structural Composite Lumber Core

SCLC-HPDL-3 Bonded  
FSCLC-HPDL-3 Non-Bonded

SCLC-HPDL-5 Bonded  
FSCLC-HPDL-5 Non-Bonded

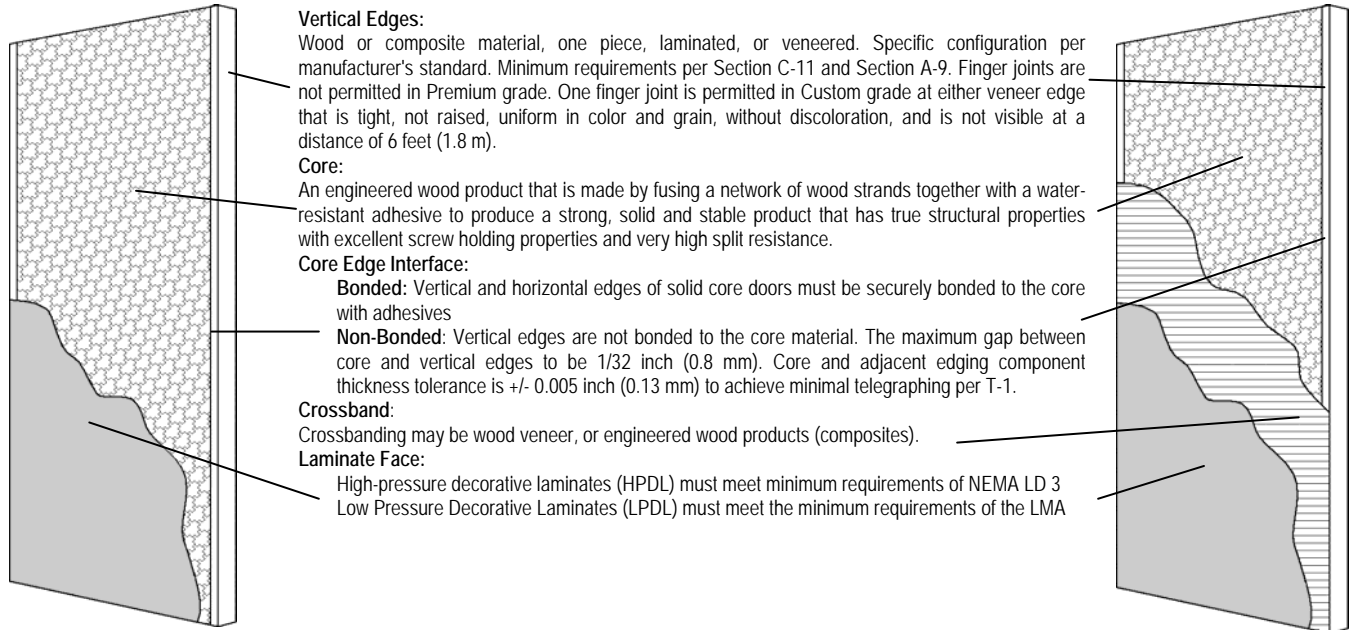

### Vertical Edges:

Wood or composite material, one piece, laminated, or veneered. Specific configuration per manufacturer's standard. Minimum requirements per Section C-11 and Section A-9. Finger joints are not permitted in Premium grade. One finger joint is permitted in Custom grade at either veneer edge that is tight, not raised, uniform in color and grain, without discoloration, and is not visible at a distance of 6 feet (1.8 m).

### Core:

An engineered wood product that is made by fusing a network of wood strands together with a water-resistant adhesive to produce a strong, solid and stable product that has true structural properties with excellent screw holding properties and very high split resistance.

### Core Edge Interface:

**Bonded:** Vertical and horizontal edges of solid core doors must be securely bonded to the core with adhesives

**Non-Bonded:** Vertical edges are not bonded to the core material. The maximum gap between core and vertical edges to be 1/32 inch (0.8 mm). Core and adjacent edging component thickness tolerance is +/- 0.005 inch (0.13 mm) to achieve minimal telegraphing per T-1.

### Crossband:

Crossbanding may be wood veneer, or engineered wood products (composites).

### Laminate Face:

High-pressure decorative laminates (HPDL) must meet minimum requirements of NEMA LD 3 Low Pressure Decorative Laminates (LPDL) must meet the minimum requirements of the LMA

## HPDL Staved Lumber Core

SLC-HPDL-5 Bonded  
FSLC-HPDL-5 Non-Bonded

### Top and Bottom Horizontal Edges:

Wood or composite material meeting the minimum requirements per Section C-11 and Section A-9. End rail species matching to stiles must be specified if required.

### Vertical Edges:

Wood or composite material, one piece, laminated, or veneered. Specific configuration per manufacturer's standard. Minimum requirements per Section C-11 and Section A-9. Finger joints are not permitted in Premium grade. One finger joint is permitted in Custom grade at either veneer edge that is tight, not raised, uniform in color and grain, without discoloration, and is not visible at a distance of 6 feet (1.8 m).

### Core:

Made with any combination of blocks or strips, not more than 2-1/2 inches (64 mm) wide, of one species of wood glued together (in butcher block fashion\_) with joints staggered in adjacent rows.

### Core Edge Interface:

**Bonded:** Vertical and horizontal edges of solid core doors must be securely bonded to the core with adhesives

**Non-Bonded:** Vertical and horizontal edges are not bonded to the core material. The maximum gap between core and vertical and/or horizontal edges to be 1/32 inch (0.8 mm). Core and adjacent edging component thickness tolerance is +/- 0.005 inch (0.13 mm) to achieve minimal telegraphing per T-1.

### Crossband:

Crossbanding may be wood veneer, or engineered wood products (composites).

### Laminate Face:

High-pressure decorative laminates (HPDL) must meet minimum requirements of NEMA LD 3 Low Pressure Decorative Laminates (LPDL) must meet the minimum requirements of the LMA



Illustrations on this page reprinted with permission from the Architectural Woodwork Institute, Reston, Virginia

## Wood Veneer Hollow Core

FIHC-5 or FIHC-7  
Institutional

FSHC-7  
Standard

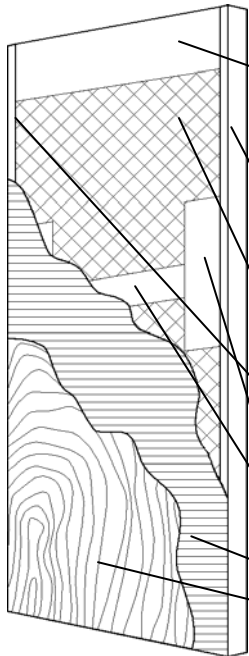

**Top and Bottom Horizontal Edges:**

Wood or composite material, meeting the minimum requirements per Section C-11 and Section A-9. End rail species matching to stiles must be specified if required.

**Vertical Edges:**

Wood or composite material, one piece, laminated, or veneered. Specific configuration per manufacturer's standard. Minimum requirements per Section C-11 and Section A-9. Finger joints are not permitted in Premium grade. One finger joint is permitted in Custom grade at either veneer edge that is tight, not raised, uniform in color and grain, without discoloration, and is not visible at a distance of 6 feet (1.8 m).

**Core:**

Often made of expanded honeycomb made of corrugated fiberboard (illustrated). Consult individual manufacturers for additional options. The material and arrangement of interior core support items are intended to prevent telegraphing in compliance with Section T-1.

**Core Edge Interface:**

**Non-Bonded:** Vertical and horizontal edges are not bonded to the core material. The maximum gap between core and vertical and/or horizontal edges to be 1/32 inch (0.8 mm). Core and adjacent edging component thickness tolerance is +/- 0.005 inch (0.13 mm) to achieve minimal telegraphing per T-1.

**Blocking Reinforcement**

**Midrail**

**Back Veneer: (3-ply skin)**

**Crossband:**

Crossbanding may be wood veneer, or engineered wood products (composites).

**Veneer Face:**

Face veneer meeting requirements per Section C-1.

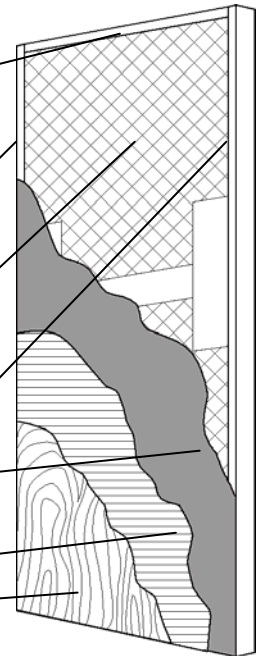

## HPDL Hollow Core

FIHC-HPDL-5  
Institutional

FSHC-HPDL-7  
Standard

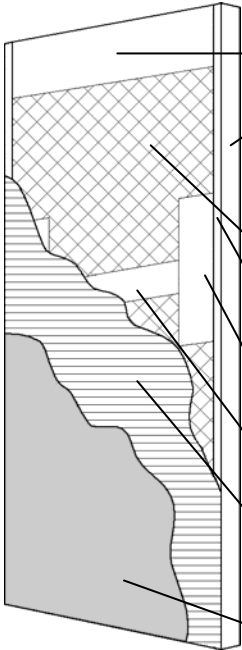

**Top and Bottom Horizontal Edges:**

Wood or composite material, meeting the minimum requirements per Section C-11 and Section A-9. End rail species matching to stiles must be specified if required.

**Vertical Edges:**

Wood or composite material, one piece, laminated, or veneered. Specific configuration per manufacturer's standard. Minimum requirements per Section C-11 and Section A-9. Finger joints are not permitted in Premium grade. One finger joint is permitted in Custom grade at either veneer edge that is tight, not raised, uniform in color and grain, without discoloration, and is not visible at a distance of 6 feet (1.8 m).

**Core:**

Often made of expanded honeycomb made of corrugated fiberboard (illustrated). Consult individual manufacturers for additional options. The material and arrangement of interior core support items are intended to prevent telegraphing in compliance with Section T-1.

**Core Edge Interface:**

**Non-Bonded:** Vertical and horizontal edges are not bonded to the core material. The maximum gap between core and vertical and/or horizontal edges to be 1/32 inch (0.8 mm). Core and adjacent edging component thickness tolerance is +/- 0.005 inch (0.13 mm) to achieve minimal telegraphing per T-1.

**Blocking Reinforcement**

**Midrail**

**Back Veneer: (3-ply skin)**

**Crossband:**

Crossbanding may be wood veneer, or engineered wood products (composites).

**Laminate Face:**

High-pressure decorative laminates (HPDL) must meet minimum requirements of NEMA LD 3 Low Pressure Decorative Laminates (LPDL) must meet the minimum requirements of the LMA



Illustrations on this page reprinted with permission from the Architectural Woodwork Institute, Reston, Virginia

# FINISHING

## General

Finishes protect wood from moisture, handling, and harsh chemicals. The sooner moisture is restricted from entering or leaving, the longer wood lasts and the finer it looks. It should be noted, however, that finishing only retards moisture penetration, it will not prevent it. Finishes described in this Section are intended for interior applications only.

Transparent finishes without stain provide a protective "window" for the wood, maintaining its natural look. Transparent finishes with stain provide the architect or designer an opportunity to create a striking visual effect by modifying the color, look, and sheen of the door. Opaque finishes protect the wood and provide a solid color painted appearance.

A finish can be applied to flush wood doors in the controlled environment of the door manufacturer's plant, or it can be applied in the field by a painting contractor.

The majority of architectural wood doors are now finished at the factory as opposed to the jobsite. It is highly recommended that specifications require factory finishing to achieve the best overall door appearance and durability.

## F-1: Factory Finishing

Factory finishing is generally specified when a project requires high quality performance and superior appearance. Factory finishing offers many benefits.

- Factory finishing utilizes state-of-the-art equipment in a dust-free environment provides uniform color, texture, and sheen - conditions normally unavailable in the field.
- Often in field finishing, numerous limitations prevent proper sanding. If improperly sanded, a door lacks the clarity of finish and uniformity of color that is achieved by factory finishing.
- Factory finishing provides adequate drying time in a dust free environment.
- Door manufacturing facilities are subject to strict State and Federal environmental standards which result in the proper handling, application, and disposal of finishing materials. Specifying factory finish improves environmental compliance.
- Factory finishing ensures that wood is protected from unfavorable moisture conditions at the earliest possible time.
- In most cases, the cost of factory finishing is lower than the cost of using a separate finishing contractor.
- Factory finished doors can immediately be installed after delivery, which means faster project completion.

## F-2: Finish Selection

Normally, door manufacturers will only supply their standard finishing system. The factory finishing information provided by the specified door manufacturer should be consulted before specifying the type and extent of finishing desired.

Section P1 of this standard identifies varying minimum finish systems for doors based on their performance duty level. However, many door manufacturers supply a TR-6/OP-6 or TR-8/OP-8 finish system as their standard finish regardless of duty level. These systems provide the highest levels of wear and chemical resistance at an economical cost. Other systems are available, based on individual door manufacturer's processes and policies.

Non-standard stain colors to match architect's selection are available from most manufacturers. Some manufacturers may offer more than one finish system or grain textures (i.e., open grain or filled grain). Specifying non-standard finishes may increase the cost over standard finishes. Should special door finishes be desired, they must be fully described in the specifications.

Since appearance and other finish characteristics are somewhat subjective, just the selection of a finishing system does not ensure that the final finish will be acceptable. Selection of a finish should be based on physical samples provided by the door manufacturer.

## F-3: Finish System Descriptions

A variety of wood finishes are available, from single stains to multi-step processes. When selecting a finish, consider the desired appearance, exposure, and maintenance it will require.

By identifying a particular finish system, an expectation of performance characteristics for the factory finish is established. There are eight finishing systems that are commonly referenced for architectural wood flush doors. These are:

- TR-2 & OP-2 (Catalyzed Lacquer)
- TR-4 & OP-4 (Conversion Varnish)
- TR-6 & OP-6 (Catalyzed Polyurethanes)
- .....TR-8 & OP-8 (UV Cured Acrylated Polyester/Urethanes)

The performance levels established by specifying one of these systems can be found in the table located in Section F-7. Finish performance levels can also be specified by referencing the duty level identified in this same table. Unless otherwise specified, manufacturers will furnish their standard finish system.

This standard is not an attempt to identify all available finish systems, or to limit the types of finishes which may be offered by door manufacturers. Other formulations may exhibit similar performance characteristics as the systems described in this Section, but must meet or exceed the performance levels for the system specified to be considered as equal. Also, the listing of a finish system in this standard does not imply compliance with the requirement of Local and/or Federal Environmental Protection Agencies.

Finishes are available in different bases and curing methods. The basic types are solvent, water reducible or ultra violet cure. Solvent bases cure by the evaporation of volatile organic compounds (VOC's) into the atmosphere and their use is regulated by environmental agencies. Water base systems evaporate water for curing. Ultra violet (UV) finishes are cured using light to create a chemical reaction within the finishing material. UV finishes are typically the most environmentally friendly of the systems used for architectural door production finishing.

Common finishing systems used by many door manufacturers are described below. "TR" indicates a transparent finish, while "OP" indicates an opaque finish.

### TR-2 & OP-2 Catalyzed Lacquer

Catalyzed lacquer systems contain an ingredient for faster drying and harder film. They have the strength and higher solids of conversion coatings. Vinyl lacquer systems are catalyzed lacquers that have a vinyl resin rather than a nitrocellulose base.

### TR-4 & OP-4 Conversion Varnish

Conversion varnish is a high solids catalyzed alkyd based coating, offering high resistance to chemicals, moisture, and scratches. Similar in composition to catalyzed lacquer, except for nitrocellulose, the solids in this finish make it economical; one coat of conversion varnish can equal two coats of lacquer. Conversion varnishes are also available in waterborne formulations.

### TR-6 & OP-6 Catalyzed Polyurethane

Catalyzed polyurethanes have higher solids content than lacquers and provide high build and excellent hardness, providing one of the highest chemical wear and impact resistance ratings of all available finishes. These finishes are very durable and offer excellent chemical, mar, and impact resistance. Many door manufacturers provide a catalyzed polyurethane system that is cured using ultraviolet (UV) technology.

### TR-8 & OP-8 UV Cured Acrylated Polyester/Urethane

Since polyesters have strong filling, build, leveling, and hardness traits, they can be combined with polyurethanes to achieve high gloss and endurance. This finish system excels in appearance, burnish, texture, and overall durability and is the highest rated performance of all the standard door finishes

## F-4: Sample Submission

Door manufacturers will provide standard colors for selection.

To specify non-standard colors and sheens, the architect is to provide two or more samples at least 8 inches x 8 inches (200 x 200 mm) showing the desired effect on the wood species and cut of veneer to be used.

Samples are to bear identification of the project and door supplier. The door manufacturer may elect to submit samples in sets of two or more, illustrating the possible range of variations. Exposure to sunlight and ultraviolet light will cause changes in wood by accelerating bleaching and oxidation. Approved finish samples must be covered and protected from effects of light during the period between approval and delivery of the finished doors.

Variations in color and appearance can be expected due to the nature of wood. Barber pole effect in book matched veneers is not a defect, but is a result of tight and loose sides of veneer created during the slicing process. This can affect color from veneer leaf to veneer leaf within a door face because of light reflection and stain absorption.

Color variation from door to door due to veneers from different logs, color variation within veneers from the same log, and variations from heartwood and sapwood, can also cause differences in appearance from door to door and are acceptable in standard door grades. Specification of uniform color and grain or flitch selection can narrow color variation.

Some veneers are susceptible to grain variations (typically end grain) which can cause a blotchy or uneven color appearance. The darker the stain, the more prevalent the variation can be. Veneers that are more likely to exhibit this effect are Birch and Maple, although it can present itself in any species. Proper sanding can reduce, but not entirely eliminate, the contrast in color.

## F-5: Job Site Finishing

Because of the many uncontrollable variables that exist at a job site, such as temperature, dust and other factors, door manufacturers' warranties do not cover the appearance of finishes applied in the field. See Section J1 for information on field finishing.

## F-6: Visual Inspection Standards

Architectural flush door faces sometimes require touch up due to natural, manufacturing or installation marks. The chart below outlines the allowable defects based on visual inspection from a described distance.

Factory finished doors must be final inspected in the vertical position, at the opening, viewed under lighting identical to final job site conditions, prior to installation.		
Defect Type	Premium Grade	Custom Grade
Glue Spots	Not permitted	Not permitted
Fine Sanding Scratches	Not permitted	Not noticeable at 3 feet (0.9 m)
Finish runs, orange peel, blisters, blushing, cracking, sags or checking	Not permitted	Not permitted
Filled holes or splits	Not noticeable at 3 feet (0.9 m)	Not noticeable at 6 feet (1.8 m)
Repair or touch-up	Not noticeable at 3 feet (0.9 m)	Not noticeable at 6 feet (1.8 m)

## F-7: Standard Wood Door Finishing System Ratings

The ratings described in the following chart indicate overall performance scores to provide the specifier with a guide to select the system that meets the resistance needs of the project. These systems are those typically available from architectural door manufacturers. Other systems may be available upon request, subject to individual manufacturer's capabilities. Specify system number and chemical description for clarity, i.e., TR-6 Catalyzed Polyurethane.

CHEMICAL / WEAR	SYSTEM NAME / NUMBER							
	Catalyzed Lacquer		Conversion Varnish		Catalyzed Polyurethane		UV Cured Acrylated Polyester/Urethane	
	Transparent	Opaque	Transparent	Opaque	Transparent	Opaque	Transparent	Opaque
	TR-2	OP-2	TR-4	OP-4	TR-6	OP-6	TR-8	OP-8
Vinegar	5	5	5	5	5	5	5	5
Lemon Juice	5	5	5	5	5	5	5	5
Orange Juice	5	5	5	5	5	5	5	5
Catsup	5	5	5	5	5	5	5	5
Coffee	5	5	5	5	5	5	5	5
Olive Oil	5	5	5	5	5	5	5	5
Boiling Water	5	5	5	5	5	5	5	5
Cold Water	5	5	5	5	5	5	5	5
Nail Polish Remover	3	3	4	4	4	4	5	5
Household Ammonia	5	5	5	5	5	5	5	5
VM&P Naphtha	5	5	5	5	5	5	5	5
Isopropyl Alcohol	3	3	5	5	5	5	5	5
Wine	5	5	5	5	5	5	5	5
Windex™	4	4	5	5	5	5	5	5
409 Cleaner™	4	4	5	5	5	5	5	5
Lysol™	5	5	5	5	5	5	5	5
33% Sulfuric Acid	5	5	5	5	5	5	5	5
77% Sulfuric Acid	3	3	1	1	4	4	4	4
28% Ammonium Hydroxide	3	3	5	5	5	5	5	5
Gasoline	5	5	5	5	5	5	5	5
Murphy's Oil Soap™	5	5	5	5	5	5	5	5
Vodka 100 Proof	5	5	5	5	5	5	5	5
1% Detergent	5	5	5	5	5	5	5	5
10% TSP	5	5	4	4	5	5	5	5
<b>TOTAL</b>	<b>110</b>	<b>110</b>	<b>114</b>	<b>114</b>	<b>118</b>	<b>118</b>	<b>119</b>	<b>119</b>
Wear Index	4	3	5	5	5	4	5	4
Cold Check	5	5	5	5	5	5	5	5
Adhesion	5	5	5	5	5	5	5	5
<b>SCORE</b>	<b>124</b>	<b>123</b>	<b>129</b>	<b>129</b>	<b>133</b>	<b>132</b>	<b>134</b>	<b>133</b>

The chemical and wear resistance characteristics of these eight standard door finishing systems were evaluated in an ISO 9000 certified laboratory using the following ASTM test criteria: Chemical Resistance Testing - ASTM D1308; Wear Index - Abrasion Resistance Testing - ASTM D4060; Cold Check Resistance - ASTM D1211; Cross Hatch Adhesion - ASTM D3359. Base line data for application prior to testing: A - 45 - 55% humidity at 70 - 80 degrees Fahrenheit (21 - 26 degrees Celsius); B - Water borne coatings must be cured in a dehumidified atmosphere and can be assisted with Infrared light and good air movement.

Performance indicator numbers on the Standard Wood Door Finishing Systems chart are used, with the following definitions:

**For Chemical Resistance and Wear Index - Abrasion Resistance:**

- 5 - No effect from the test
- 4 - Minimal effect or slight change and little repair required
- 3 - Some effect, noticeable change and the coating will recover with minimal repairs
- 2 - Moderate effect, performance adversely affected and repairs required
- 1 - Poor performance and film failure is imminent and repairs difficult

**For Cross Hatch Adhesion**

- 5 - Edges of the cuts are completely smooth; none of the squares of the lattice is detached
- 4 - Small flakes of the coating are detached at intersections; less than 5% of the area is affected
- 3 - Small flakes of the coating are detached along edges and at intersections of cuts; 5 to 15% of the area is affected
- 2 - Coating has flaked along the edges and on parts of the squares; 15 to 35% of the area is affected
- 1 - Coating has flaked along the edges of the cuts in large ribbons and whole squares have detached; 35 to 65% of the area is affected.

# JOB SITE INFORMATION



## HOW TO STORE, HANDLE, FINISH, INSTALL AND MAINTAIN WOOD DOORS

### CARE AND INSTALLATION AT JOB SITE

To preserve the fine qualities of wood doors and a lifetime of superior service, proper storage, handling, finishing and installation is very important. The following guidelines will help to maintain the high quality products supplied by wood door manufacturers.

### STORAGE AND HANDLING

1. Store doors flat on a level surface in a dry, well-ventilated building. Doors should not come in contact with water. Doors should be kept at least 4 in. (102 mm) off the floor with cross supports and should have protective coverings under the bottom door and over the top. Covering should protect doors from dirt, water and abuse but allow for air circulation under and around the stack.
2. Avoid exposure of interior doors to direct sunlight. Certain species (e.g., cherry, mahogany, walnut, and teak) in an unfinished state are more susceptible to discoloration if exposed to sunlight or some forms of artificial light. To protect doors from light damage after delivery, opaque wrapping of individual doors may be specified.
3. Do not subject interior doors to extremes of heat and/or humidity. Do not allow doors to come in contact with water. Prolonged exposure may cause damage. Buildings where humidity and temperature are controlled provide the best storage facilities (recommended conditions 25%-55% RH and 50°F-90°F (10°C to 32°C).
4. Do not install doors in buildings that have wet plaster or cement. Do not store doors in buildings with excessive moisture content. HVAC systems should be operating and balanced
5. Doors should always be handled with clean dry hands or while wearing clean dry gloves.
6. Doors should be lifted and carried when being moved, not dragged across one another.

### FINISHING

1. Wood is hygroscopic and dimensionally influenced by changes in moisture content caused by changes within its surrounding environment. To assure uniform moisture exposure and dimensional control, all surfaces must be finished equally.
2. Doors should not be considered ready for finishing when initially received. Before finishing, remove all handling marks, raised grain, scuffs, burnishes and other undesirable blemishes by block sanding all surfaces in a horizontal position with 120, 150 or 180 grit sandpaper. Solid core flush doors, due to their weight, naturally compress the face veneer grain while in the stack. Therefore, sanding of the overall surface will be required to open the veneer grain to receive a field applied finish evenly. To avoid cross grain scratches, sand with the grain.
3. Certain species of wood, particularly oak, may contain extractives which react unfavorably with foreign materials in the finishing system. Do not use steel wool on bare wood, rusty containers or any other contaminate in the finishing system.
4. A thinned coat of sanding sealer should be applied prior to staining to promote a uniform appearance and avoid sharp contrasts in color or a blotchy appearance. Door manufacturers are not responsible for the final appearance of field-finished doors. It is expected that the painting contractor will make adjustments as needed to achieve desired results.
5. All exposed, unfinished wood surfaces should be finished and the top and bottom rails sealed, as required by manufacturer's finishing instructions. Cutouts for hardware in exterior doors and doors located adjacent to areas where high moisture is expected should be sealed prior to installation of hardware.
6. Dark colored finishes should be avoided on all surfaces if the door is exposed to direct sunlight, in order to reduce the chance of warping or veneer checking.
7. Water-based coatings on unfinished wood may cause veneer splits, highlight joints and raise wood grain. If used on exterior doors, the coating should be an exterior grade product. When installed in exterior applications, doors must be properly sealed and adequately protected from the elements. Please follow the finish and door manufacturer's recommendations regarding the correct application and use of these products.
8. Be sure the door surface being finished is satisfactory in both smoothness and color after each coat. Allow adequate drying time between coats. Desired results are best achieved by following the finish manufacturer's recommendations. Do not finish doors until a sample of the finish has been approved.
9. Certain wood fire doors have fire retardant salts impregnated into various wood components that make the components more hygroscopic than normal wood. When exposed to high moisture conditions, these salts will concentrate on exposed surfaces and interfere with the finish. Before finishing the treated wood, reduce moisture content below 11% and remove the salt crystals with a damp cloth followed by drying and light sanding.



## INSTALLATION

1. The utility or structural strength of the doors must not be impaired when fitting to the opening, applying hardware, or preparing for lites, louvers, plant-ons or other detailing.
2. Use two hinges for solid core doors up to 60 inches (1524 mm) in height, three hinges up to 90 inches (2286 mm) in height or portion thereof. Interior hollow core doors weighing less than 50 lbs. (23 kg) and not over 90 inches (2286 mm) in height may be hung on two hinges. Use heavy weight hinges on doors over 175 lbs. (79 kg). Pivot hardware may be used in lieu of hinges. Consult hinge or pivot hardware manufacturer with regard to weight and size of hinges or pivots required.
3. The maximum clearance between the top, hinge edge and lock edge to the frame and meeting edge of pairs of doors, is 1/8 inch (3.2 mm).
4. All hardware locations, preparations and methods of attachment must be appropriate for the specific door construction. Templates for specific hardware preparation are available from hardware manufacturers or their distributors.
5. When lite or louver cutouts are made for exterior doors, they must be protected in order to prevent water from entering the door core.
6. Pilot holes must be drilled for all screws that act as hardware attachments. Full threaded screws are preferable for fastening hardware to non-rated doors and are required on fire-rated doors. Self-tapping or combination wood/metal screws are not to be used on wood doors.
7. In fitting non-rated doors for height, do not trim top or bottom edge by more than 3/4 inch (20 mm) unless accommodated by additional blocking. Trimming of fire-rated doors must be in accordance with NFPA 80
8. Doors and door frames should be installed plumb, square and level.

## CLEANING AND TOUCHUP

1. Inspect all wood doors prior to hanging them on the job. Repair noticeable marks or defects that may have occurred from improper storage and handling.
2. Field repairs and touchups are the responsibility of the installing contractor upon completion of initial installation. Field touchup shall include the filling of exposed nail or screw holes, re-finishing of raw surfaces resulting from job fitting, repair of job inflicted scratches and mars and final cleaning of finished surfaces.
3. When cleaning door surfaces, use a non-abrasive commercial cleaner designed for cleaning wood door or paneling surfaces that does not leave a film residue that would build up or affect the surface gloss of the door finish.

## ADJUSTMENT AND MAINTENANCE

1. Insure that all doors swing freely and do not bind in their frame. Adjust the finish hardware for proper alignment, smooth operation and proper latching without unnecessary force or excessive clearance.
2. Review with the owner/owner's representative how to periodically inspect all doors for wear, damage and natural deterioration.
3. Review with the owner/owner's representative how to periodically inspect and adjust all hardware to insure that it continues to function as it was originally intended.
4. Finishes on exterior doors may deteriorate due to exposure to the environment. In order to protect the door, it is recommended that the condition of the exterior finish be inspected at least once a year and re-finished as needed. Both exterior and interior finishes will change color over time.

401 N. Michigan Avenue, Suite 2200, Chicago, IL 60611  
[www.wdma.com](http://www.wdma.com)



# REFERENCE STANDARDS AND ORGANIZATIONS

## ADA

Americans with Disabilities  
Disability Rights Section Mailing Address  
U.S. Department of Justice  
950 Pennsylvania Avenue, NW  
Civil Rights Division  
Disability Rights Section - NYA  
Washington, D.C. 20530  
[www.usdoj.gov](http://www.usdoj.gov)

## ANSI

American National Standards Institute, Inc.  
25 West 43rd Street, 4th floor  
New York, NY 10036  
[www.ansi.org](http://www.ansi.org)

**ANSI A135.4 – 04** *Basic Hardboard*

**ANSI A208.1 – 09** *Particleboard*

**ANSI A208.2 – 09** *Medium Density Fiberboard (MDF) for Interior Applications*

## ASTM

American Society for Testing and Materials  
100 Barr Harbor Drive  
P.O. Box C700  
West Conshohocken, PA 19428-2959  
[www.astm.org](http://www.astm.org)

**ASTM D1308 - 02(2007)** *Standard Test Method for Effect of Household Chemicals on Clear and Pigmented Organic Finishes*

**ASTM D3359 - 09** *Standard Test Methods for Measuring Adhesion by Tape Test*

**ASTM D4060 - 10** *Standard Test Method for Abrasion Resistance of Organic Coatings by the Taber Abraser*

**ASTM E90 - 09** *Standard Test Method for Laboratory Measurement of Airborne Sound Transmission Loss of Building Partitions and Elements*

**ASTM E413 - 10** *Classification for Rating Sound Insulation*

## AWI

Architectural Woodwork Institute  
1952 Isaac Newton Square West  
Reston, VA 20190  
[www.awinet.org](http://www.awinet.org)

**Architectural Woodwork Standards, 1<sup>st</sup> Edition**

## FSC

Forest Stewardship Council – U.S.  
212 Third Avenue North, Suite 504 Minneapolis, MN 55401  
[www.fscus.org](http://www.fscus.org)

## GBI

Green Globes  
The Green Building Initiative  
2104 SE Morrison  
Portland, Oregon 97214  
[www.thegbi.org](http://www.thegbi.org)

## HPVA

Hardwood Plywood & Veneer Association  
1825 Michael Faraday Drive  
Reston, VA 20290  
[www.hpva.org](http://www.hpva.org)

ICC  
International Code Council  
500 New Jersey Avenue, NW, 6th Floor  
Washington, DC 20001-2070  
www.iccsafe.org  
**International Building Code (IBC) – all editions**

NEMA  
National Electrical Manufacturers Association  
1300 North 17th Street, Suite 1847  
Rosslyn, VA  
www.nema.org  
**ANSI/NEMA LD-3 – 05 High-Pressure Decorative Laminates (HPDL)**

NFPA  
National Fire Protection Association  
1 Batterymarch Park  
Quincy, MA 02169  
www.nfpa.org  
**NFPA 80 – 10 Standard for Fire Doors and Other Opening Protectives**  
**NFPA 101 – 09 Life Safety Code**  
**NFPA 105 – 10 Standard for the Installation of Smoke Door Assemblies and Other Opening Protectives**  
**NFPA 252 – 08 Standard Methods of Fire Tests of Door Assemblies**  
**NFPA 5000 – 09 Building Construction and Safety Code**

NIJ  
National Institute of Justice  
810 Seventh Street, NW  
Washington, DC 20531  
www.ojb.usdoj.gov/nij

SCS  
Scientific Certification Systems  
2200 Powell Street, Suite 725  
Emeryville, CA 94608  
www.scscertified.com

SFI  
Sustainable Forestry Initiative, Inc.  
900 17<sup>th</sup> Street, NW, Suite 700  
Washington, DC 20006  
www.sfiprogram.org

UL  
Underwriters Laboratories, Inc.  
333 Pfingsten Road  
Northbrook, IL 60062  
www.ul.com  
**UL 10B – 08 Standard for Fire Tests of Door Assemblies**  
**UL 10C – 09 Standard for Positive Pressure Fire Tests of Door Assemblies**  
**UL 752 – 05 Standard for Bullet-Resisting Equipment**  
**UL 1784 – 01 Standard for Air Leakage Tests of Door Assemblies**

USGBC  
U.S. Green Building Council  
1800 Massachusetts Avenue NW, Suite 300  
Washington, DC 20036  
www.usgbc.org  
**LEED – Leadership in Energy and Environmental Design**

WDMA  
Window & Door Manufacturers Association  
401 North Michigan Ave.  
Chicago, IL 60611-4267  
www.wdma.com

**WDMA I.S. 6A-08** *Industry Standard for Architectural Stile and Rails Doors*

**WDMA I.S. 10-05** *Industry Standard for Testing Cellulosic Composite Materials for Use in Fenestration Products*

**WDMA T.M. 6-08** *Test Method for Determining the Durability of Adhesives Used in Doors under Accelerated Aging Conditions*

**WDMA T.M. 7-08** *Test Method for Determining the Physical Endurance of Wood Doors and Associated Hardware Connections under Accelerated Operating Conditions*

**WDMA T.M. 8-08** *Test Method for Determining Hinge Loading Resistance of Wood Door Stiles*

**WDMA T.M. 10-08** *Test Method for Determining the Screw Holding Capacity of Wood Doors*

**WDMA T.M. 15-11** *Test Method for Determining the Vertical Edge Impact Resistance of Backing for Veneered Wood Door Stiles*

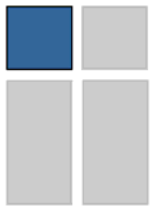

**WINDOW & DOOR  
MANUFACTURERS ASSOCIATION**

**WDMA**

401N. Michigan Avenue, Suite 2200, Chicago, IL 60611  
[www.wdma.com](http://www.wdma.com)